

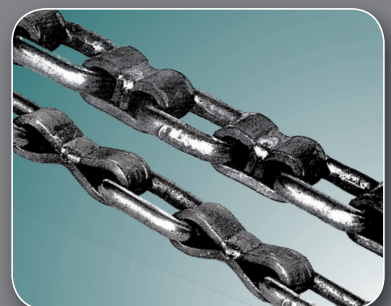

## B - Drop forged and round-link chains

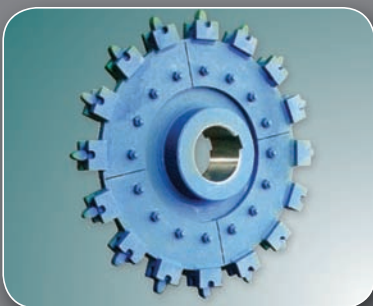

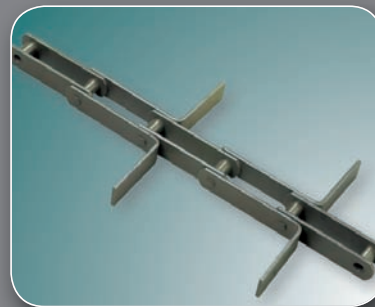

## B - Drop forged and round-link chains

- Chain wheels
- Scraper attachments
- Cast sprockets for round-link chains
- Drag chains and scraper chains

• Scope & some examples	B2
• Typical chain conveyors TKT	B3 - B5
• Drop forged scraper-chains and sprockets	B6 - B15
• Engineered pin-bush scraper-chains	B16 - B22
• Wear- and guiding strips	B23 - B24
• Cast drag-chains and sprockets	B25 - B26
• Round link steel chains, shackles and sprockets	B27 - B40
• Technical information, maintenance, erection and wear	B41
• Round-link steel chains, guides, etc.. for multi-purpose	B42 - B43
• Cast sprockets for round link chains	B44 - B46
• Special coupling chains pitch 80 & 100 mm and sprockets	B47 - B51





DROP FORGED



Scraper chain pitch 250 mm for cement Industry

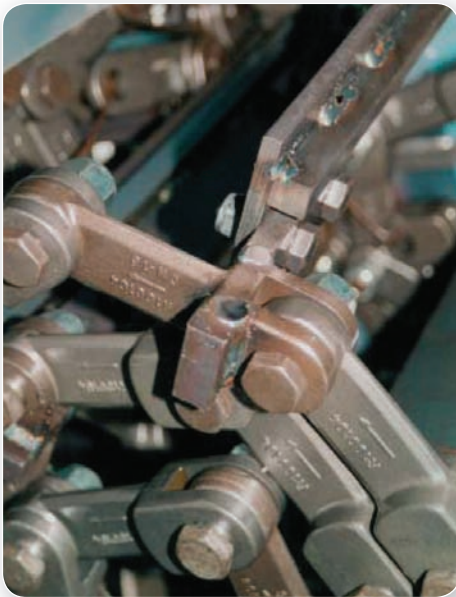

Scraper-chains  
Drag-chains  
and Sprockets



## GEHA - Chain conveyors TKT

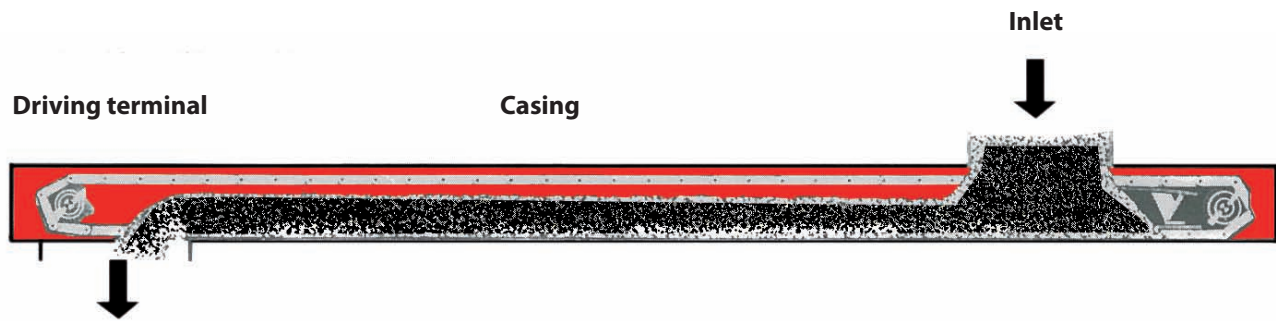

GEHA chain conveyors are economic and dependable in operation, simple and sturdy of construction and only require the least possible maintenance. For bulk transport, their uses are virtually unlimited. No qualified staff is required to operate GEHA chain conveyors.

Outstanding features of the GEHA chain conveyors are:

1. Clean and dustless operation
2. Considerable saving of space
3. Minimum maintenance required
4. No risk of damage to the material handled
5. Automatic infeed control
6. Largely self-sustaining construction
7. Possibility of transporting materials at high temperatures
8. No risk of explosion
9. Low rate of energy consumption



## Some of the most typical GEHA chain conveyor arrangements

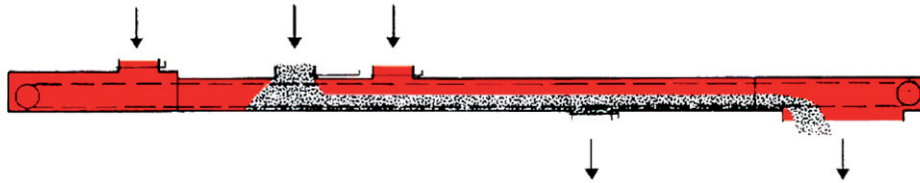

### Single-bottomed horizontal chain conveyors.

Simple and economic bulk conveyors in double- or triple-strand execution featuring conveying capacities up to 1000 t/h. Since the return chain requires only a minimum of space, the full height of the channel is available for the material to be handled. Working distances up to 180 metres.

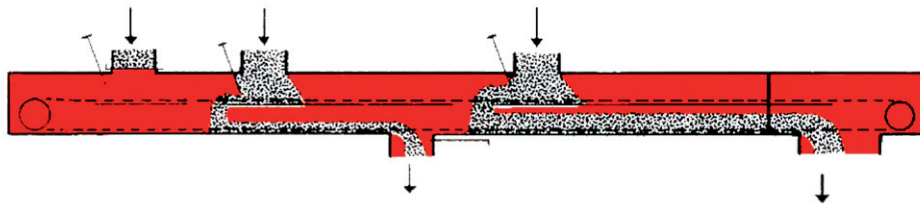

### Double-bottomed horizontal chain conveyors.

For simultaneous two-way transport to mix different products in varying quantities and proportions without pulverizing the material handled. Several controllable infeed openings allow this equipment to be used for mixing and dosaging purposes. The equipment can also be arranged for carrying the material to several outlets.

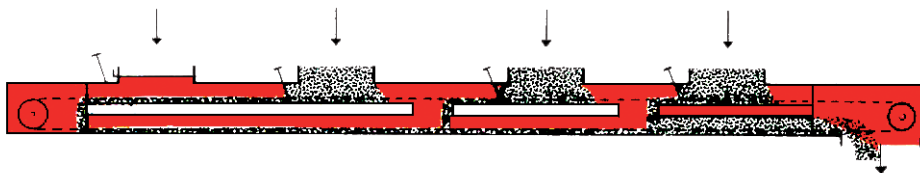

### Two-channel horizontal chain conveyor.

This equipment offers the same possibilities as the aforementioned conveyor, but it was designed to be used in special circumstances, i.e. for bridging other equipment, cables, pipes, buildings etc.

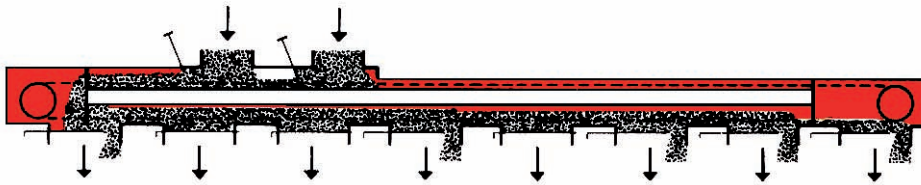

**The chain conveyor used as mixing and distributing equipment.**

This arrangement is mainly used in flour mills, corn silos and oil mills. Its working principle is based on placing several chain conveyors one over the other to mix the material in the proportion required and then carry it to the silo or bunker selected for storage.



**Simple combined sloping/horizontal chain conveyor.**

A variant of the horizontal chain conveyor. The material to be handled is fed into the inlet opening, drops through the upper chain and is then carried away by the lower chain in a sweeping movement. Since there is hardly any friction between the particles of the material handled, the risk of pulverization is largely eliminated.

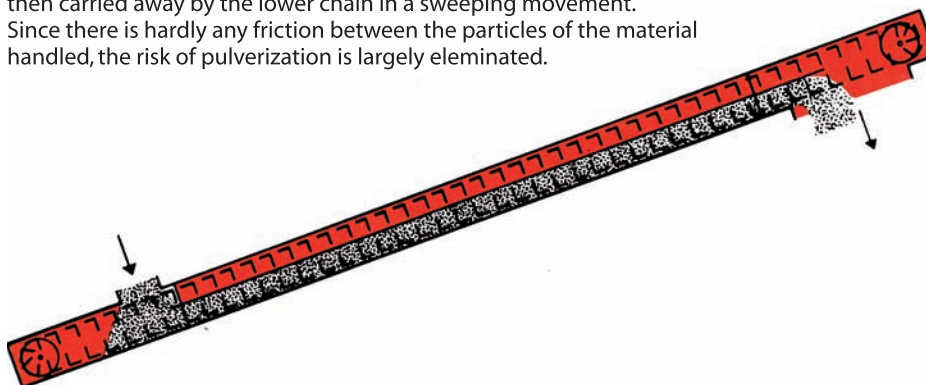

**Double-bottomed sloping chain conveyor.**

The U-shaped chainflights of this equipment ensure a smooth material supply, even when the equipment has to be used in a very upright position. The conveyor has been provided with a partition so that the full height of the lower channel will carry the material handled.



# The chain

DROP FORGED

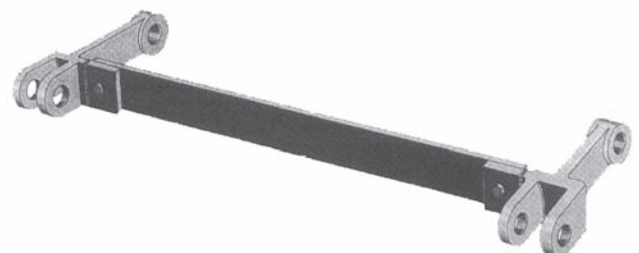
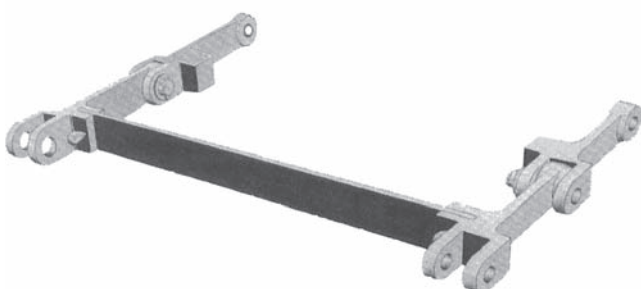
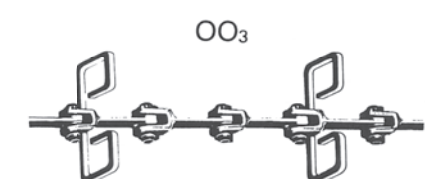
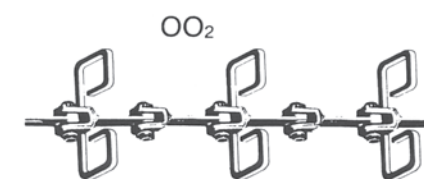
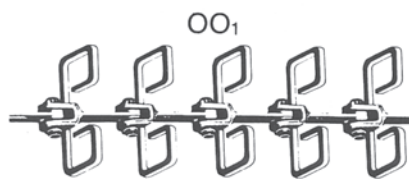
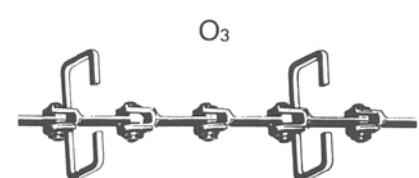
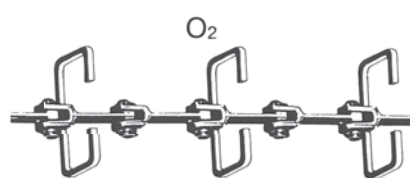
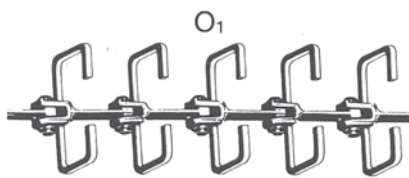
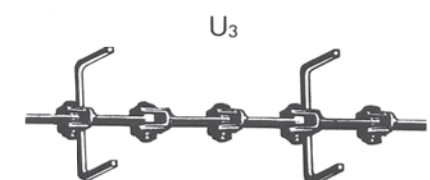
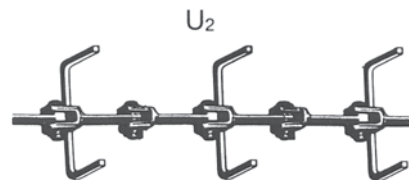
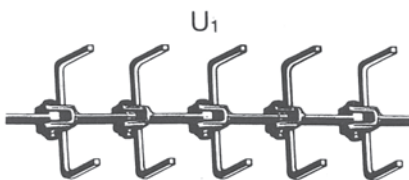
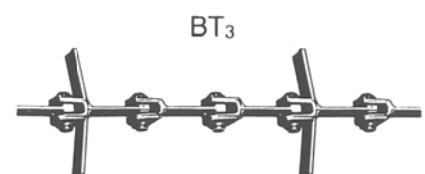
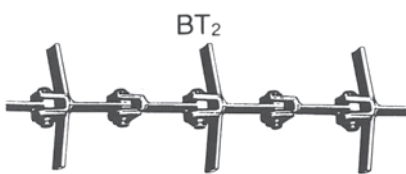
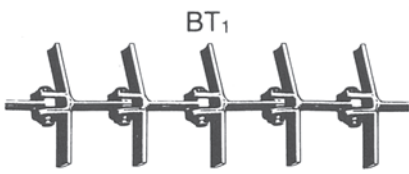
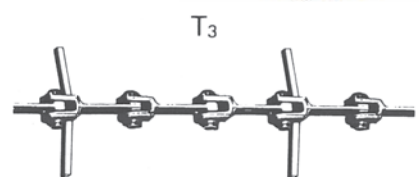
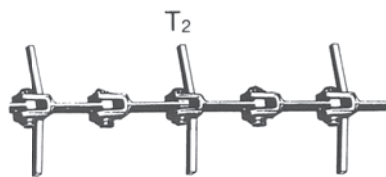
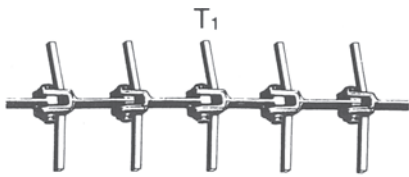



## The chain

Already more than 45 years we are specialised in the production of drop-forged and other scraperchains and sprockets.

Scraperchains can be used for conveying a large scale of products. It works also in fine dusty products till heavy bulk-materials, stone, coal etc... dry and wet.

Column-flow drop-forged chain is mostly used in the industry for example by following products: cement, fertilizers, chemicals, minerals, sugar, coal, ashes, sand, food, woodships, waste, sludge, gypsum, etc...

Depending of the utilisation of medium, you can make a choice between several types of steel-qualities in accordance with the product to be handled.

- For light and non-abrasive products a chain made from carbon-steel will be sufficient (C45).
- For the food-industry we can offer chains made from stainless-steel.
- For very abrasive products we propose a chain made from hardened alloy steel (20 MnCr 5 and 18 NiCrMo 5 case-hardened).
- Also for products with higher temperature (between 250 and 400°C) we can offer you chains made of special alloyed steel (by example out of 42 CrMo 4). And at last we make chains out of heat-resistant alloyed steels for products of 400° up to 1000°C.

On the opposite page you see sever all types of scrapers which are welded on the link. The choice of the scapertype depends of the conveyor-angle and the product to be handled.

- For example, using horizontal conveyors we foresee scrapers out of flat or square material (type T and BT)
- For inclined to vertical conveyors we foresee bended scrapers – see types O and OO.
- For extremely fluid products we can make closed scrapers.
- For other applications such as extraction purpose or very large conveyors, we can offer double-strand chains also whith a large scale of scrapers, depending of the product to be handled.

The linear chain-speed is determined to by the product to be handled. For very abrasive products such as sand, gravel or ashes, the chain speed should not be higher than 0,05 till 0,1 m/s. For cereals, rice and so on, higher speeds are allowed (0,8 m/s or more). Important to know is that the chain-speed depends also on the length of the conveyor and if there are 1 or more bends.

Great advantages of column-flow chain conveyors are: dust-tight, small section of casing for high capacities, maintenance-free and important: the possibility to have several inlets and outlets.

One important remark for choosing a drop-forged chain is that, not only the breaking-load is to be calculated, but more important is the bearing area surface in the articulations of the chain-links (see  $f(\text{cm}^2)$ ) listed with each type of chain hereafter.

Please consult us for all chain-conveying projects and also for choosing the right type of chain for your bulk solids to be handled.





## Drop forged chain

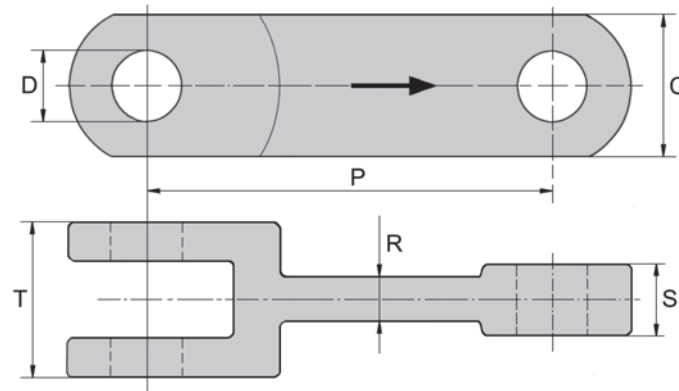

### SINGLE STRAND

Type		P Pitch mm	T mm	C mm	S mm	f cm <sup>2</sup>	R mm	D mm	Breaking l. kN MAX. <sup>(1)</sup>
66102		101,6	24	36	9	1,26	6	14	130
66102/R		101,6	30	36	13	1,82	9	14	200
67125/R		125	37	37	15	3,76	10	16	235
69216		142	46	40	20	4,40	13	22	250
69218		142	42	50	19	4,63	13	25	340
69222		142	54	50	25	6,25	16	25	380 <sup>(2)</sup>
69226		142	62	50	28	7,00	15	25	500
69290		142	24	47	9	1,80	7	20	190
70010		150	36	36	15	2,70	10	18	210
70012		150	42	36	17	3,06	12	18	220
70014		150	42	47	16	4,00	12	25	300
70090		150	24	47	9	1,80	7	20	170
71018		160	46	45	23	5,06	15	22	320
71025		160	50	53	23	5,75	14	25	435
101522		160	47	45	23	4,95	15	22	270 <sup>(3)</sup>
77025		200	60	50	25	6,25	18	25	540
77028		200	66	60	29	8,70	20	30	650
73640		216	64	72	26	9,10	20	35	700
74040		220	64	72	26	9,10	20	35	700
74050		220	58	75	28	8,96	25	32	600
74060		220	71	75	31	10,85	21	35	750
75040		250	70	75	32	10,88	18	34	700
76035		260	65	75	32	10,24	20	32	680
76040		260	70	75	32	10,24	20	32	700

(1) Breaking-load according material and heat-treatment

(2) This type can be supplied with an anti-rotation pin.

(3) Special model

f(cm<sup>2</sup>) = articulation surface

#### Note:

- Some of these models can work in both directions (nd. Reversible chain).
- Most of above chains can be supplied for double strand conveyors.

#### Chain-links available in different materials:

C15, Ck45, 42Cr Mo4: tough-hardened

16Mn Cr5, 20MnCr5, 18NiCrMo5: case-hardened

stainless-steel and/or heat-resistant steel



## Drop forged chain

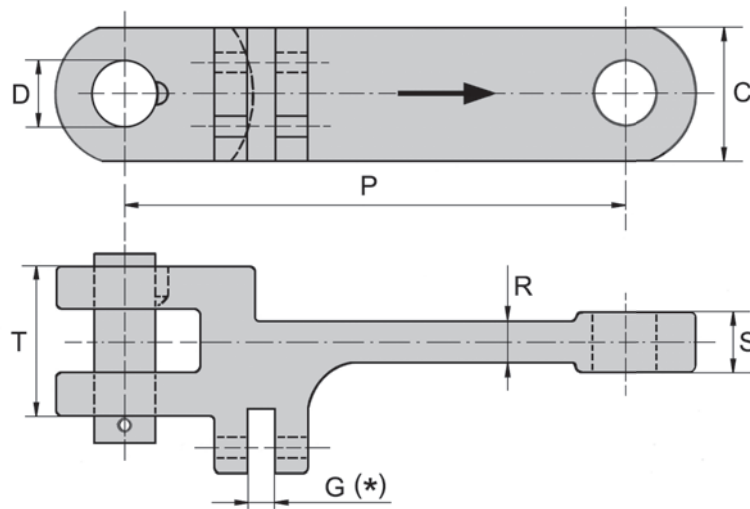

### DOUBLE STRAND

Type		P Pitch mm	T mm	C mm	S mm	f cm <sup>2</sup>	R mm	D mm	Breaking l. kN MAX. <sup>(1)</sup>
80218		142	42	50	19	4,75	13	25	340
80226		142	62	50	28	7,00	15	25	500
81025		160	60	50	25	6,25	18	25	540
101596		175	70	60	30	9,00	22	30	580 <sup>(3)</sup>
82040		175	72	60	30	9,00	23	30	600
83025		200	60	50	25	6,25	18	25	540
83040		200	70	60	30	9,00	20	30	580
84025		250	60	50	25	6,25	18	25	540
84040		250	70	60	30	9,00	20	30	580
84060		250	100	70	45	15,75	36	35	900

(1) Breaking-load according material and heat-treatment

(3) Special model

f(cm<sup>2</sup>) = articulation surface

#### Chain-links available in different materials:

- C15, Ck45, 42Cr Mo4: through-hardened
- 16Mn Cr5, 20MnCr5, 18NiCrMo5: case-hardened
- stainless-steel and/or heat-resistant steel

\* G: on request



DROP FORGED

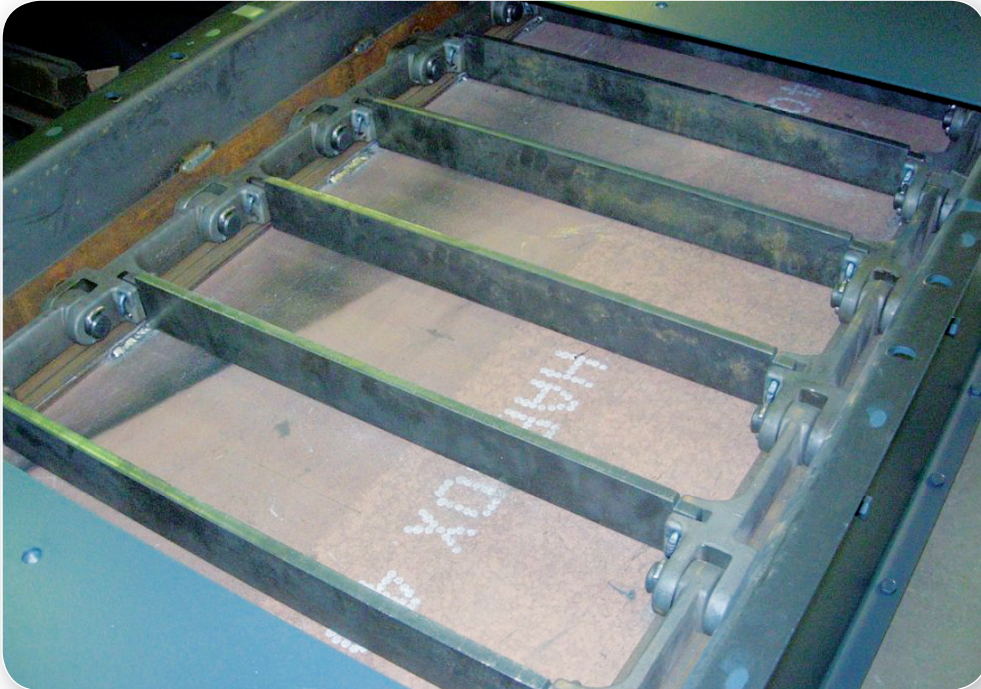

Double strand drop-forged chain pitch 200, 250, 260, etc... Bottom-plate made of Hardox 400 steel.



Scraper conveyor casing for extraction under bunker or hopper.



## Chainwheels for drive

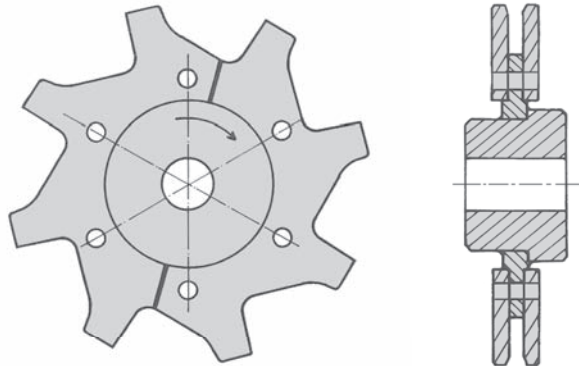

As well as the chain, the sprockets are also important in column-flow conveyors. These sprockets are available in several executions which depends on the application such as the size of the section of the auge, chain-type, product to be handled and also the accessibility of these sprockets.

The common type is a wheel with a welded hub and divided, removable toothed segments, which allows replacement of teeth without disassembling the shaft with bearings.

Conclusion: very short shut-down and production-lost; also easier and faster work for maintenance-techniciens.

Sprockets with removable toothed segments are delivered with shaftbore and slot.

Segments are available in several qualities, such as carbon-steel with hardened teeth or out of alloyed steel, like 42 CrMo 4, also with hardened teeth.

For the food- and chemical industry, we can make the sprockets out of stainless steel.

We have also a complete range of sprockets made in one single piece – see further in this catalogue; these are normally made of carbon-steel with hardened teeth – prebored.

Concerning the tension-wheels we have untoothed sprockets for the single strand chaintypes and they are also made out of carbon steel, alloyed steel or stainless steel. For the double strand chaintypes, the tension wheels should be toothed due to the asymmetric shape of the links.

Also sprockets with drums at both sides are possible, only for the cases that products must be conveyed in the upperpart of the casing.

To determine the number of teeth of the needed sprocket, there are some points to respect, such as: chain-speed, the total lenght of the conveyor, the product to be handled and the most important: the height of the scrapers welded on the chain-links (see scrapers type U, O, OO, page B-6).

Consult us before choosing your sprockets.



# Pitch diameter

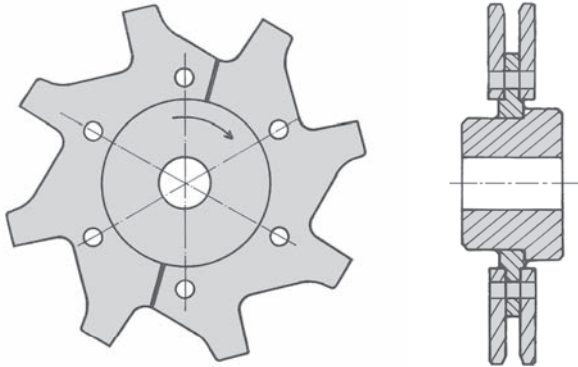

DROP FORGED

z/p	76,2	101,6	102	135	142	150	160	200	250	260
6		203	204	270	284	300	320	400	500	520
7	176	234	235	311	327	346	369	461	576	599
8	199	265	267	353	371	392	418	523	653	679
9	223	297	298	395	415	439	468	585	731	760
10	247	329	330	437	460	485	518	647	809	841
11	271	361	362	479	504	533	568	710	888	923
12	294	393	394	522	549	580	618	773	966	1005
13	318	425	426	564	593	627	669	836	1045	1087
14	342	457	458	607	638	674	719	899	1124	1168
15	366	489	491	649	683	721	769	962	1202	1250
16	391	521	523	692	728	769	820	1025	1281	1333
17	415	553	555	735	773	816	871	1088	1360	1415
18	439	585	587	777	818	864	921	1152	1440	1497
19	463	617	620	820	863	911	972	1215	1519	1580
20	487	649	652	863	908	959	1023	1279	1598	1662
21	511	682	684	906	953	1006	1073	1342	1677	1744
22	535	714	717	949	998	1054	1124	1405	1757	1827

p = pitch  
z = number of teeth

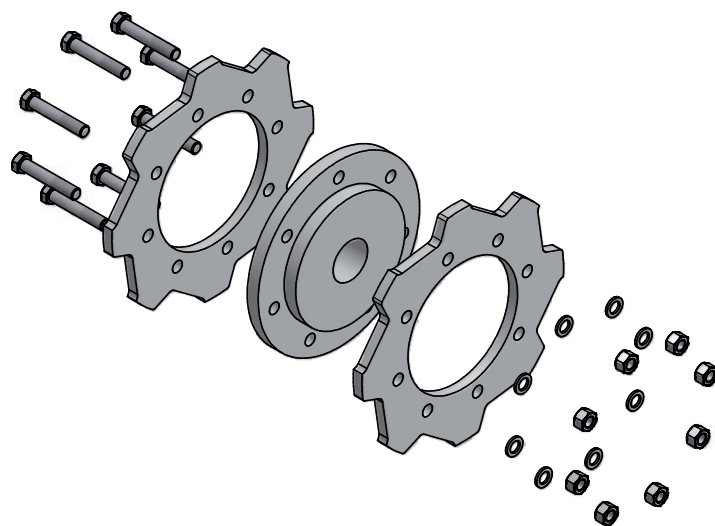



## Drive sprockets for scraper chains forged steel

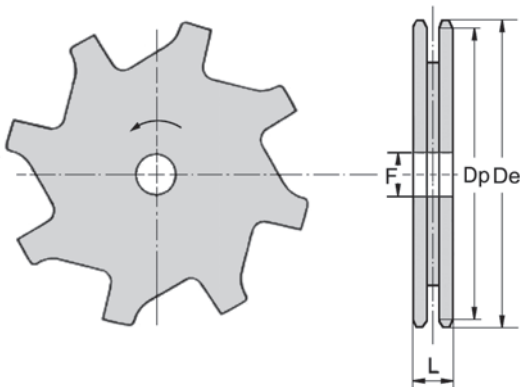

Chain	Number of teeth	Dp mm	De mm	F mm	L mm
66102	6	203,20	216	25	34
	8	265,50	275		
	10	328,80	340		
	12	392,60	405		
66102/R	6	203,20	216	25	34
	8	265,50	275		
	10	328,80	340		
	12	392,60	405		
69290	6	284,00	304	25	34
	8	371,06	390		
	10	459,52	470		
	12	548,70	570		
69218	6	284,00	304	40	50
	8	371,06	390		
	10	459,52	470		
	12	548,70	570		
69222	6	284,00	304	40	60
	8	371,06	390		
	10	459,52	470		
	12	548,70	570		
69226	6	284,00	304	50	70
	8	371,06	390		
	10	459,52	470		
	12	548,70	570		
70090	6	300,00	314	25	34
	8	391,65	406		
	10	485,55	500		
70014	6	300,00	314	25	50
	8	391,65	406		
	10	485,55	500		
71025	8	418,09	445	50	60
	10	517,77	545		
77025	8	522,40	565	70	80
	10	647,40	690		
75040	8	653,27	690	70	80
76040	8	679,40	710	70	80

These wheels are available with removable toothed segments in hardened carbon-steel or hardened alloy steel. See page B-12.

DROP FORGED



## Tension - wheels with guiding teeth

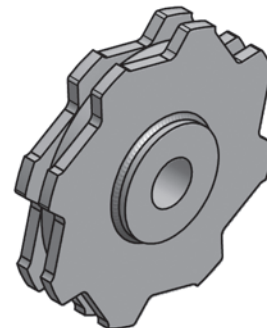
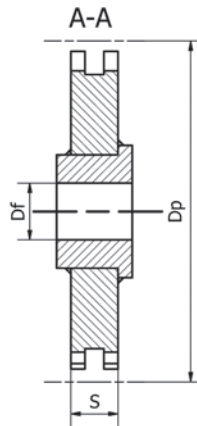
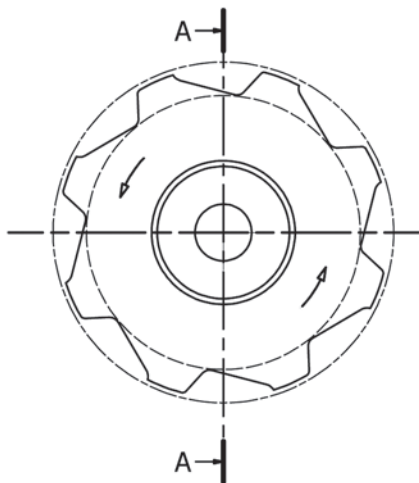
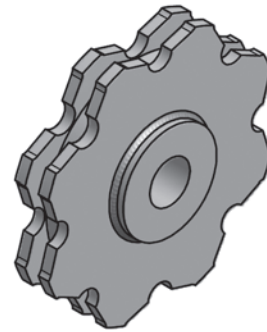
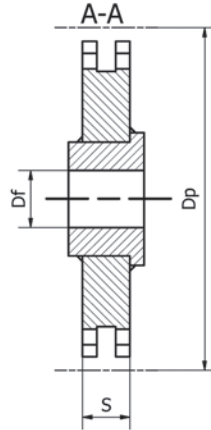
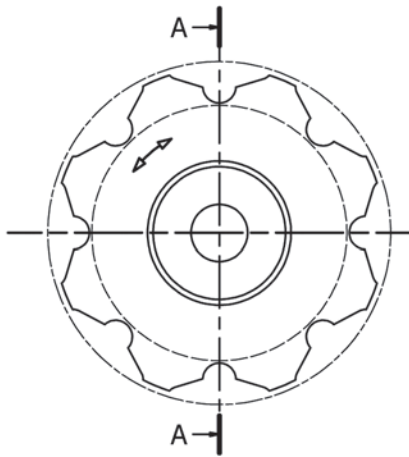

Untoothed tension- or idler sprockets are now, since the last few years, replaced by the same sprockets, but now with small guiding teeth as shown in above drawings. This is also to avoid chain-slippage on untoothed pulleys. The teeth-shape exists in 2 executions: above with reversible teeth (for working in 2 senses) and the other execution is for single sense working). Teeth are made of C45 or 42 Cr Mo 4 steel machined and induction-hardened for longer life. They can also be supplied with replaceable segments as for the drive-sprockets.

- For all types of drop-forged scraper-chains.
- Also available without teeth for sprockets with 6 teeth.



# Chain parts

DROP FORGED

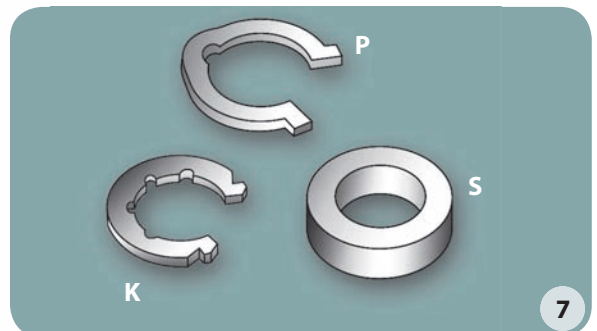
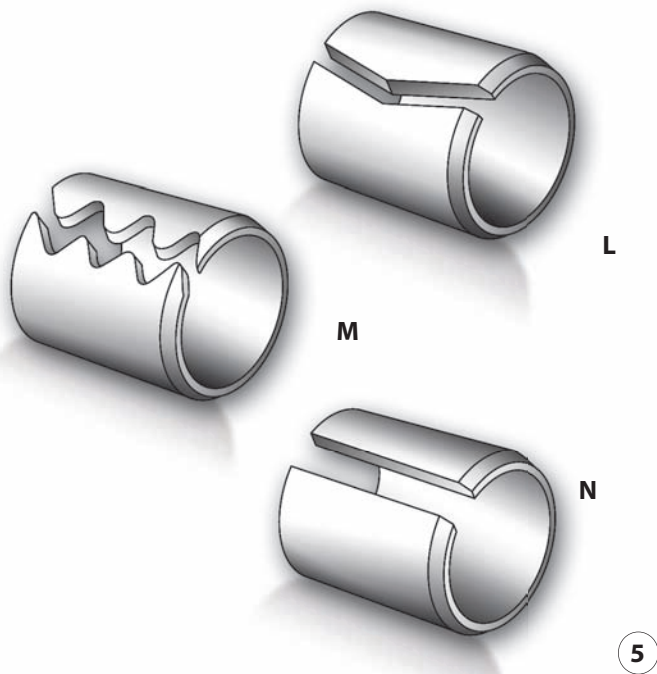
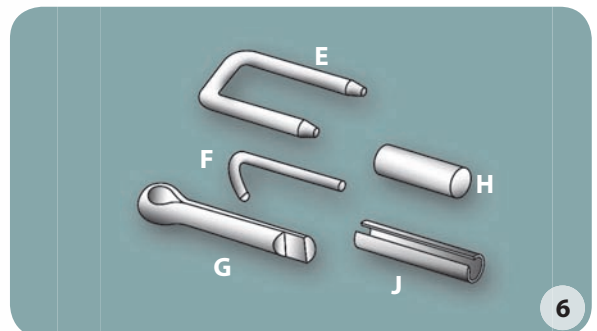
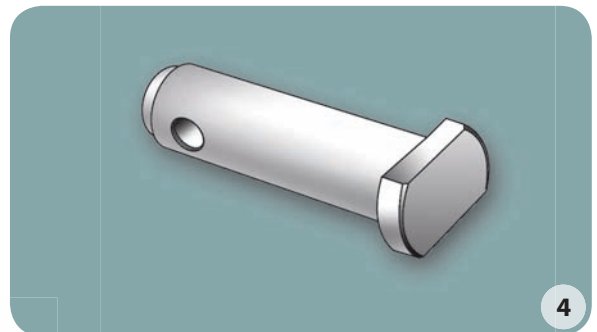
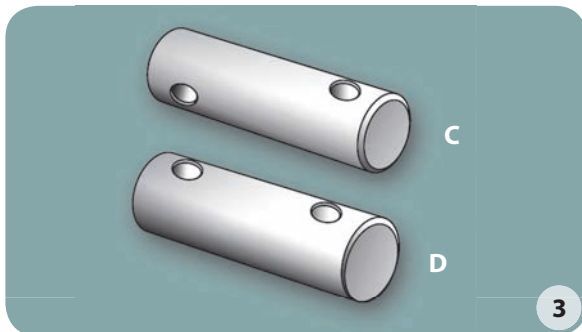
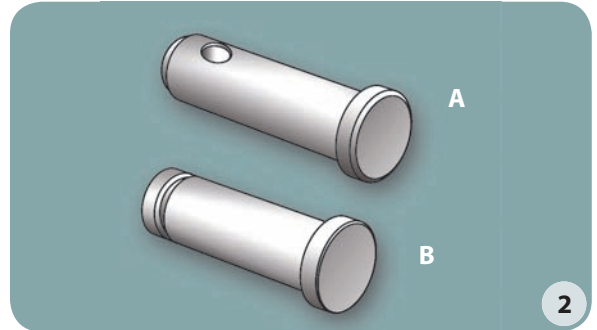
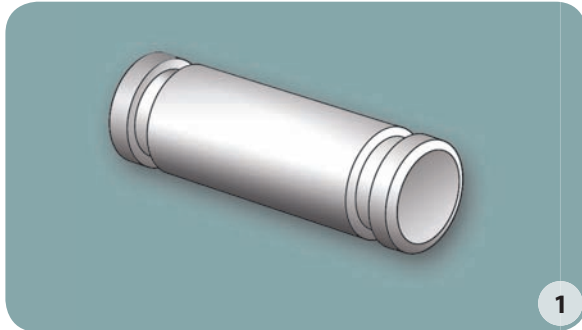





DROP FORGED

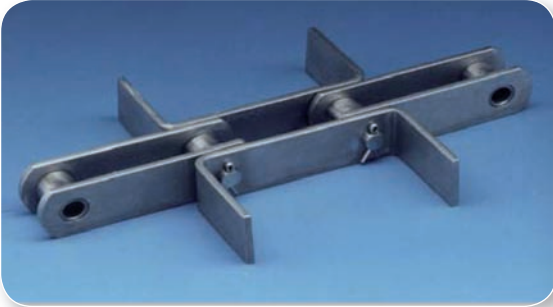
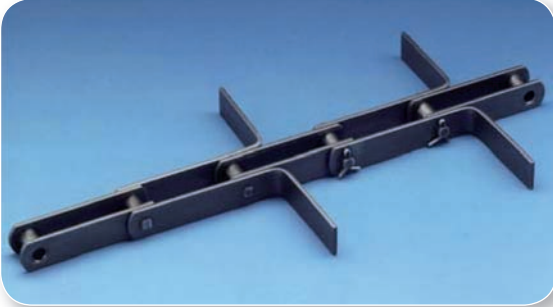

Scraper chains for colum-flow conveyors.

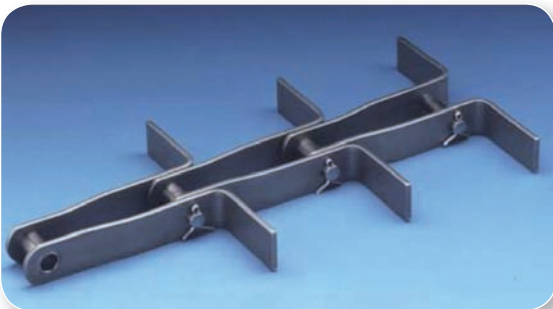
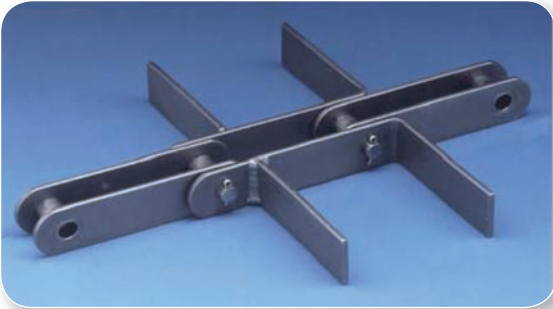



## Scraper chains - straight sideplates

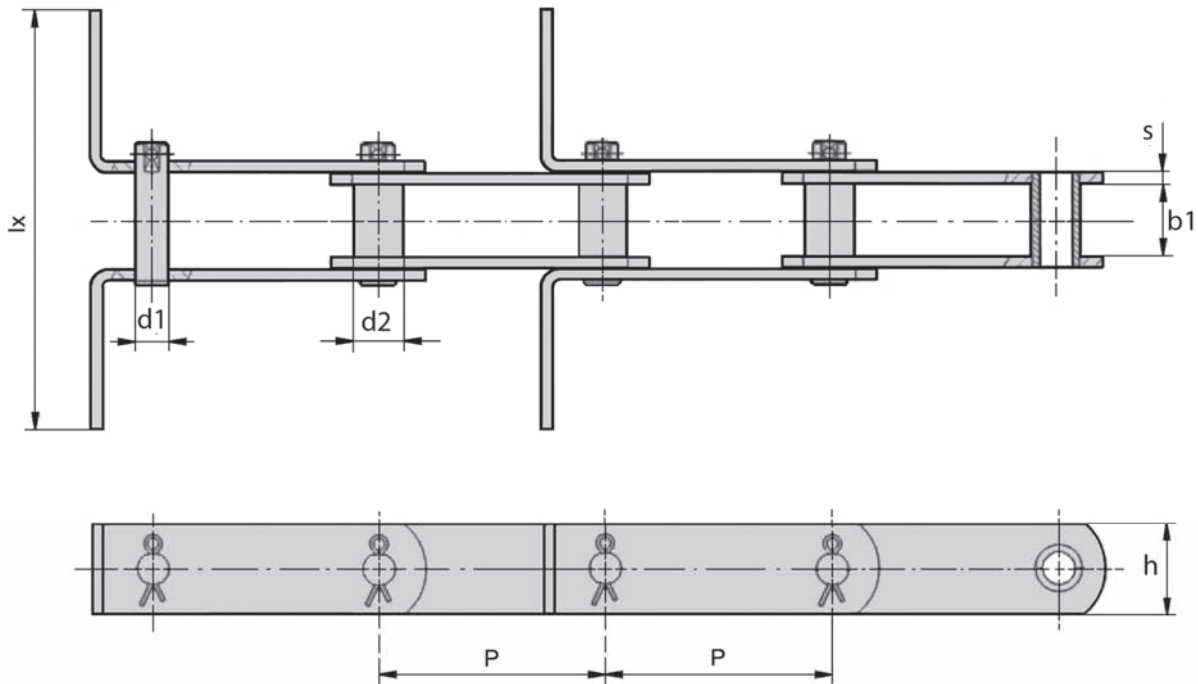

DROP FORGED

Type		$P$	$b1$	$d2$	$d1$	$h$	$s$	$lx^{(*)}$	Breaking load
		mm	mm	mm	mm	mm	mm	mm	kg <sup>(1)</sup>
10084		100	30	22	16	40	6	260	8400
12584		125							
14584		145							
15084		150							
17584		175							
20084		200							
125110		125	40	27,0	18	50	6	260	11.000
145110		145							
150110		150							
175110		175							
200110		200							
145140		145	45	30,0	20	50	8	260	14.000
150140		150							
175140		175							
200140		200							
250140		250							
150200		150	55	36	26	60	8	260	20000
175200		175							
200200		200							
250200		250							

These chains can also be manufactured with higher scrapers or in special executions also for working double and triple strand, etc. ...

(1) Also possible with higher breaking loads.

(\*) Also on application



## Conveyor chain for specific applications

The previous section describes conveyor chains and attachments that can be used for almost all general applications. This section describes conveyor chains for specific applications developed, based on conveyor chains for general applications. Conveyor chains for specific applications offer improved form, size series and material advantages that suit respective applications. They can be classified into three types: conveyor chain exclusive for specific conveyance, in-water conveyor chain and three-dimensional bent chain.

**Conveyor chain exclusive for specific conveyance.**

**Conveyor chain with attachments for bulk conveyance.**

**Continuous flow conveyor and chain for dust conveyor.**

As shown in the photo, a chain with blades is caused to travel in a powder, to let the powder flow in the same direction as the traveling direction of the chain. This is called a continuous flow conveyor. A conveyor for discharging the dust generated by various dust collectors in the same way uses a similar chain. We manufacture 25 types of chains with blades attached to conveyor chains for general applications, two types of chains with blades attached to block chains respectively suitable for the various properties of dusts and powders, and five chains with special cast steel blades for conveying powders likely to cause wear. The respective chains are designated as follows:

Conveyor chain with blades for general application

Chain for continuous flow conveyor or chain for dust conveyor

Block chain with blades

Block chain for dust conveyor

Chain with special cast steel blades

TA type drag chain

We manufacture continuous flow conveyors and dust conveyors using the above chains with blades as standard. Please consult us for further details.

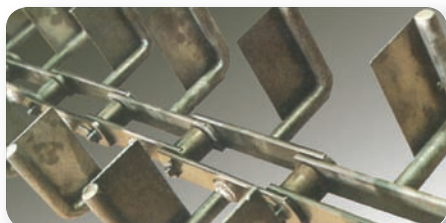



## Shapes and indications of attachments

DROP FORGED

A

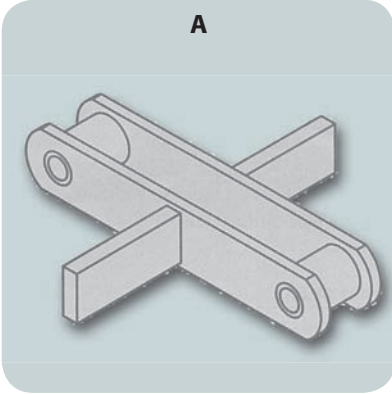

B

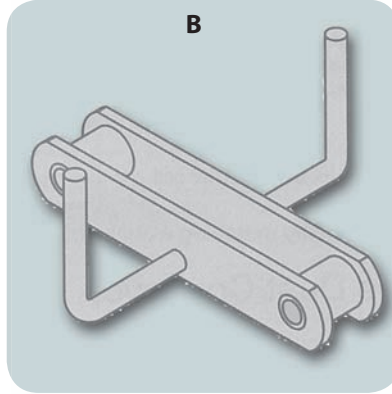

C1

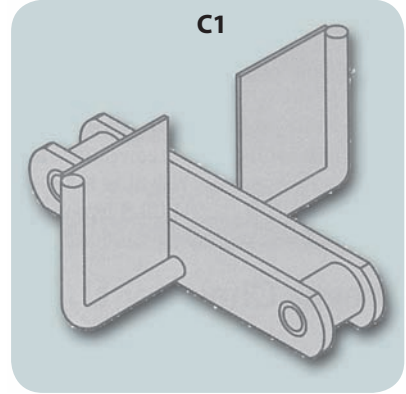

A2

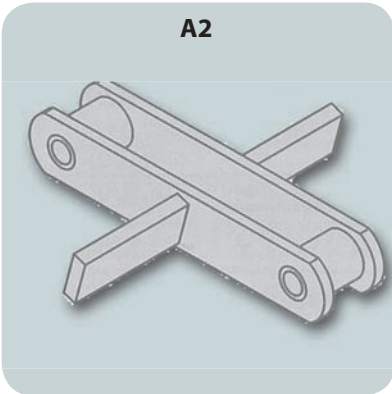

C2

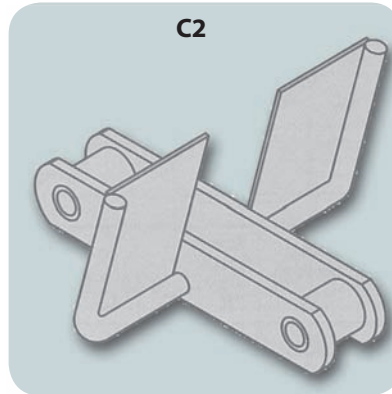

D

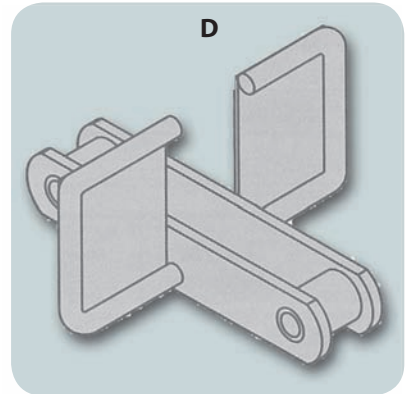

E

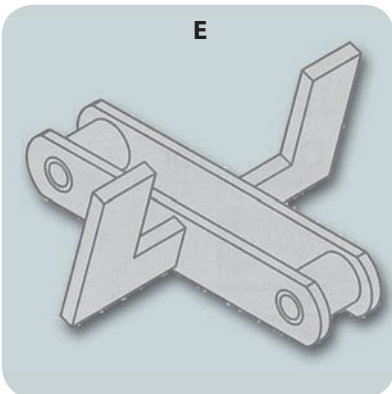



# Scraper chains - straight sideplates

## DIN 8165 European Standard

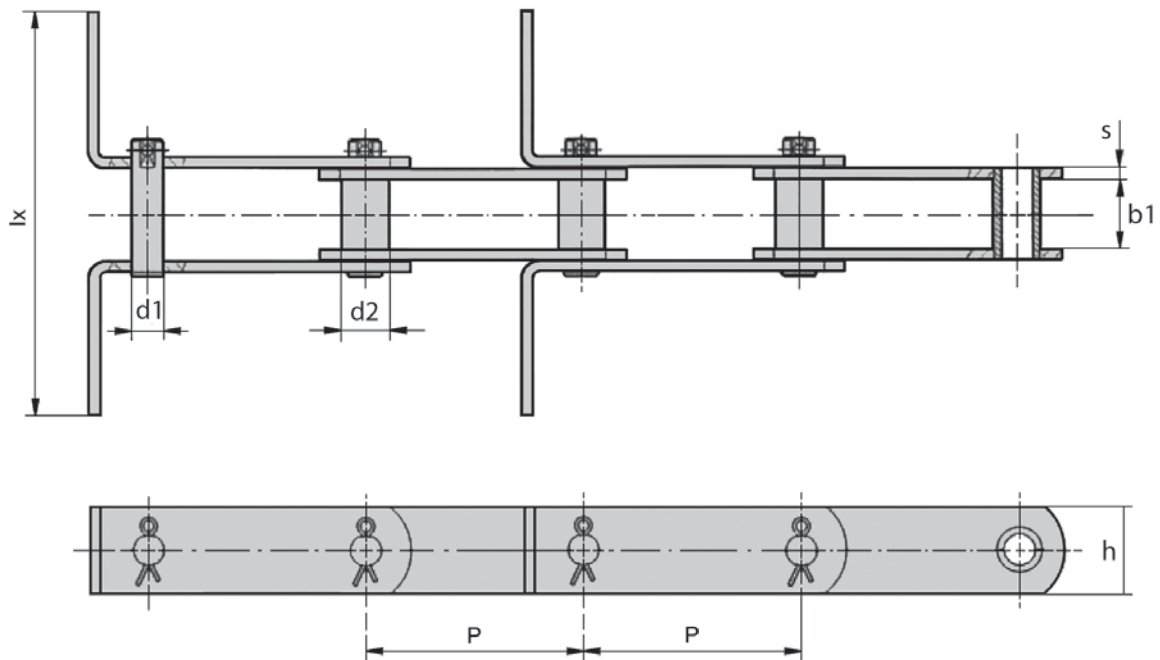

DROP FORGED

Chain No. 	Pitch				Inner width $b_1$ mm	Bearing pin $d_1$ mm	Bush $d_2$ mm	Breaking load  N	Bearing surface  $f(\text{cm}^2)$	Side plates	
	$p$									$s$ mm	$h$ mm
	mm	mm	mm	mm							
FV 40	40	63	80	100	18	10	15	40000	2,5	3	25
FV 63	63	100	125	160	22	12	18	63000	3,7	4	30
FV 90	63	100	125	160	25	14	20	90000	5,0	5	35
FV112	100	125	160	200	30	16	22	112000	6,8	6	40
FV140	100	125	160	200	35	18	26	140000	8,6	6	45
FV180	125	160	200	250	45	20	30	180000	12,3	8	50
FV250	125	160	200	250	55	26	36	250000	18,7	8	60
FV315	160	200	250	315	65	30	42	315000	25,8	10	70
FV400	160	200	250	315	70	32	44	400000	30,7	12	70
FV500	160	200	250	315	80	36	50	500000	38,2	12	80
FV630	200	250	315	400	90	42	56	630000	48,7	12	100

Lx: Scraper-large on application  
\* Welded scraper also possible



## b- Chain for dust conveyor

This chain is used for a conveyor exclusively for dust.  
Depending on the application, the following three types are available.

### 1) S Roller Conveyor Chain for low density powder:

With B or B1 attachments for U and LU Type Dust Conveyors

### 2) M Roller Conveyor Chain for medium density powder:

With KL or KUL attachments for DU, Du-S, LDU and LDU-S Type Dust Conveyors

### 3) Block Chain for highly abrasive powder:

With KL or KUL attachments for DUB, DUB-S, LDUB and LDUB-S Type Dust Conveyors

The combination of chain types and attachments simplify matching a chain and dust conveyor specifications.

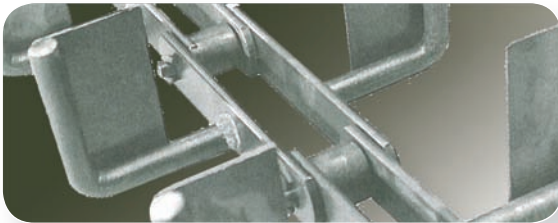

### Conveyor chain for U, LU type dust conveyor

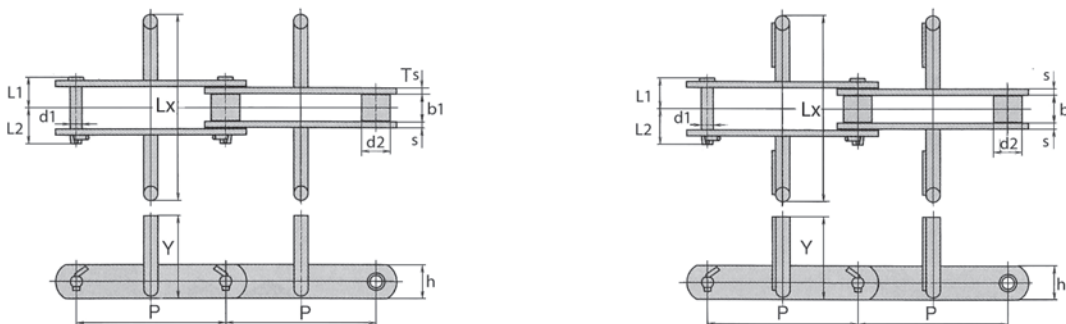

Unit (mm)

Chain No.	Type of dust conveyor	Avg. tensile strength kN (kgf)	Pitch	Inner width	Roller outside dia.	Pin			Plate		Width of wing plate	Height of wing plate	Approx. weight (kg/m)	
						d1	L1	L2	s	h			with B attachment	with B1 attachment
19152S	U-200	186	152.4	36.5	34.9	15.9	40.4	47.1	8	45	175	80	11.5	-
	LU-200	19,000											11.5	-
19200S	U-270	186	200	36.5	34.9	15.9	40.4	47.1	8	45	245	110	12.2	-
	LU-270	19,000											-	13.3
25200S	U-270	245	200	51.8	40.1	19.1	51.7	59.8	9	50	245	110	15.7	-
	LU-270												25,000	-
32200S	U-350	313	200	57.6	44.5	22.2	55.7	62.8	9	65	325	140	19	-
	LU-350												32,000	-
													23.3	-
													-	25.8



## Conveyor Chain for **DU, DU-S, LDU, LDU-S** type Dust Conveyor

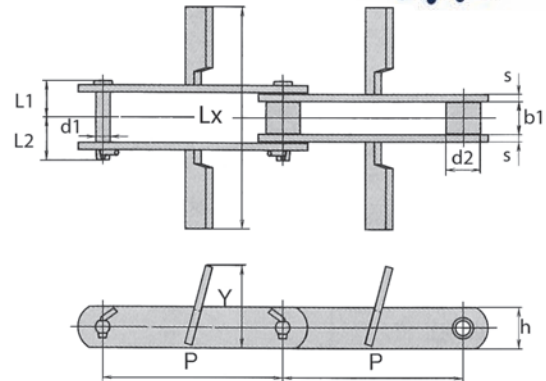
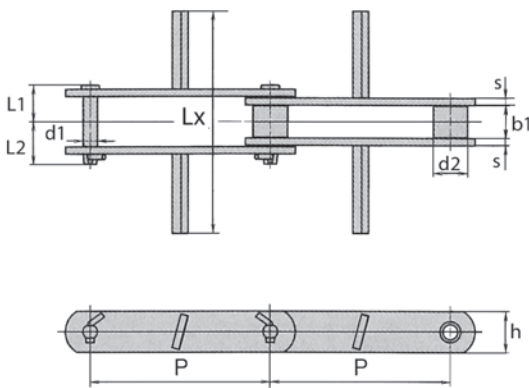

Unit (mm)

Chain No.	Type of dust conveyor	Avg. tensile strength kN (kgf)		Pitch	Inner width	Bush diameter	Pin			Plate		Width of wing plate Lx	Approx. weight (kg/m)	
							P	b1	d2	d1	L1		L2	s
19152M	DU-200 DU-200S LDU-200 LDU-200S	279 28,500		152.4	36.5	38.1	15.9	40.4	47.1	8	45	185	11.2	-
	11.2												12.6(Y=65) 13.8(Y=90)	
	DU-250 DU-250S LDU-250 LDU-250S											230	12.2	-
	12.2												13.9(Y=65) 17.0(Y=110)	
25200M	DU-310 DU-350S LDU-310 LDU-310S	392 40,000		200	51.8	44.5	19.1	51.7	59.8	9	50	290	15.0	-
	15.0												20.0(Y=110) 22.0(Y=140)	
													-	20.0(Y=110) 22.0(Y=140)

Note: It can be changed the dimension of X, Y upon request.

## Block Chain for **DUB, DUB-S, LDUB, LDUB-S** type Dust Conveyor

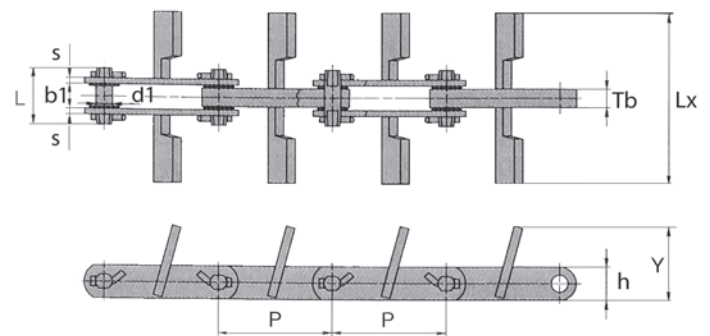
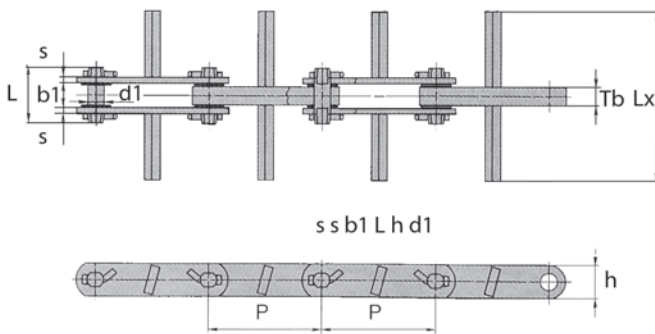

Unit (mm)

Chain No.	Type of dust conveyor	Avg. tensile strength kN (kgf)		Pitch	Inner width	Pin		Outer plate		Block		Width of wing plate Lx	Approx. weight (kg/m)	
						d1	L	s	h	Tb	h		with KL attachment	with KUL attachment
30B150	DUB-200 DUB-200S LDUB-200 LDUB-200S	294	30,000	152.4	33.3	22	76.5	8	45	25	45	185	13.5	-
	13.5												14.5(Y=65) 16.0(Y=90)	
	DUB-250 DUB-250S LDUB-250 LDUB-250S											230	14.5	-
	14.5												16.5(Y=65) 19.5(Y=100)	
40B150	DUB-310 DUB-310S LDUB-310 LDUB-310S	392	40,000	152.4	40.8	25.2	86.5	9	50	32	50	290	20.0	-
	20.0												22.3(Y=65) 27.8(Y=110)	
													-	22.3(Y=65) 27.8(Y=110)
40B200	DUB-400	392	40,000	200	40.8	25.2	86.5	9	50	32	50	380	19.6	22.0(Y=65) 27.9(Y=110)

DROP FORGED



## Wear strips

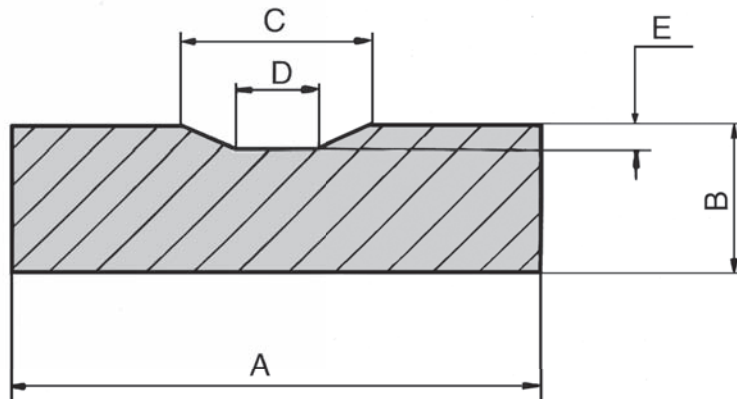

These high wear resistant strips are available to be installed under the chain, to prevent wear on the bottom-plate of the conveyor due to the friction of the chain. These strips also have a groove to center the chain and to prevent wear on the side-walls of the conveyor. The 12% Mn-strips are standard heat treated and difficult to drill, but can easily be welded<sup>(\*)</sup> on the bottom-plate. They also can be bended when needed to install in courbes of inclined or vertical conveyors. The wear-strips can also be delivered with thread taps at the underside, so they are replaceable.

If you need strips with other dimensions as those who are in the table hereunder, we can make strips out of HARDOX steel, but without groove.

Hardox strips and plates reach a hardness of maximum 560 HBr and are good weldable. Thickness from minimum 5 mm till maximum 80 mm.

<sup>(\*)</sup>Welding by stainless steel electrodes.

For all other questions, please consult our technicians.

Material: DIN 1.3401 heat treated (with 12% Manganese).

The wear strips are delivered in standard lengths of  $\pm 3$  meters.

### Dimensions

A	B	C	D	E
50	10	12	5	2mm
70	10	25	15	3mm
70	20	25	15	3mm
100	10	25	15	3mm

Other sizes on request.





## Guiding strips for scraper chain conveyors

### For pin-bush fabricated chain light/medium DIN 8165

#### Side-bars friction

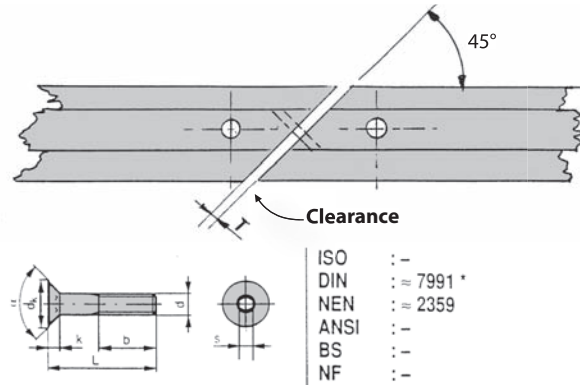
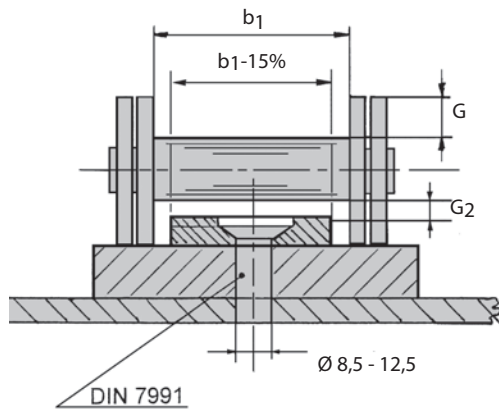

DROP FORGED

### For drop-forged chain

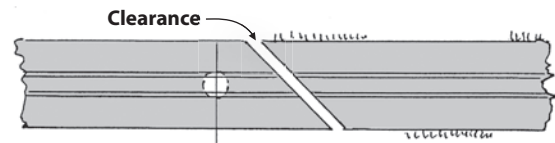
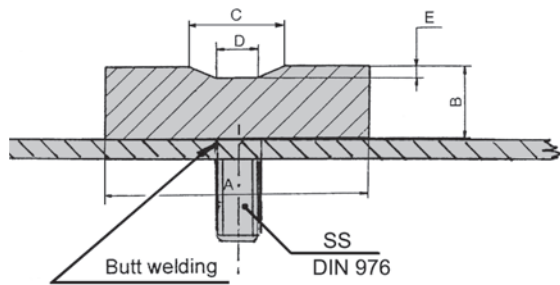

#### Dimensions

A	B	C	D	E
50	10	12	5	2mm
70	10	25	15	3mm
70	20	25	15	3mm
100	10	25	15	3mm

Material: DIN 1.3401 heat treated (with 12% Manganese).

The wear strips are delivered in standard lengths of  $\pm 3$  meters.

Other sizes on request.

### For heavy pin-bush fabricated chain DIN 8165 and DIN 8167 and works-standard

#### Bush-friction

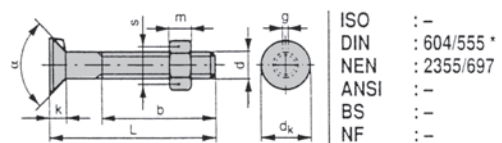
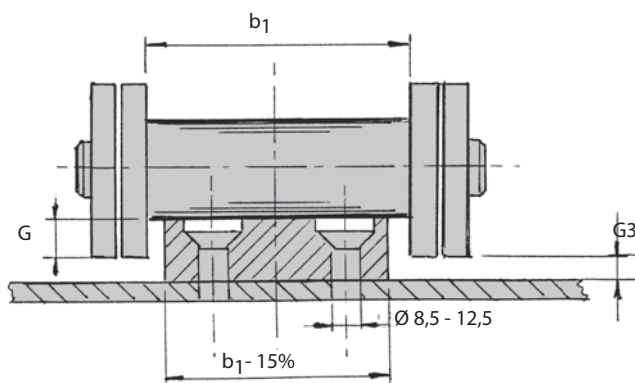



DROP FORGED



Cast drag-chain for clinker in cement-industry.



Special sprocket for drag chain with removable teeth.



# C - TA type drag chain

This chain is used for our Drag Chain Conveyor. A TA type drag Chain as a simple structure in which offset type cast blocks are connected by pins. The design is ideal for conveying large granular material and highly abrasive granular material such as cement residue or pellets in a trough, materials which cannot be easily conveyed by ordinary conveyor chain. This chain is used in many Drag Chain Conveyors, and its durability is application proven.

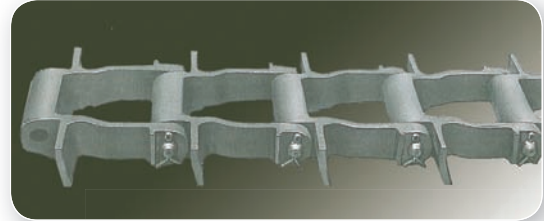

## W (Washer) Type

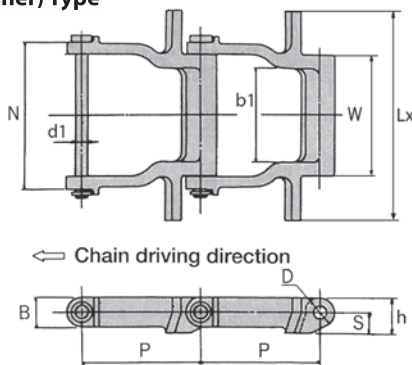

## C (T-pin) Type

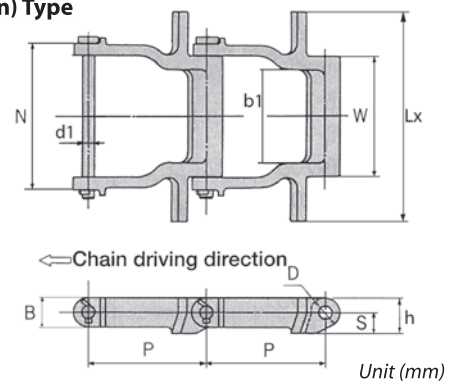

Unit (mm)

Chain No.	Avg. tensile strength		Pitch P	Dimension of parts									Approx. weight (kg/m)
	kN	kgf		Lx	W	N	b1	d1	D	B	h	S	
CC-W250150	294	30,000	150	250	120	156	90	19.1	40	40	50	30	27
CC-W350200	441	45,000	200	350	200	243	158	22	50	50	62	37	45
CC-W450200				450									49
CC-W450250				450									79
CC-W550250	980	100,000	250	550	230	312	184	34	75	75	86	48.5	84
CC-W6000250				600									86.5
CC-W650250				650									89

Note) 1. The last letter of Chain No. indicate Washer type with W, and T-pin with (C). 2. As Washer type is designated as Standard type, Washer type is delivered without any instruction. 3. This chain normally consist of 5 link as a unit to be delivered. As it is not welded between connecting pin and washer, please make welding all around of connecting pin and washer. (\*) Other chain dimensions also possible.

## Sprocket

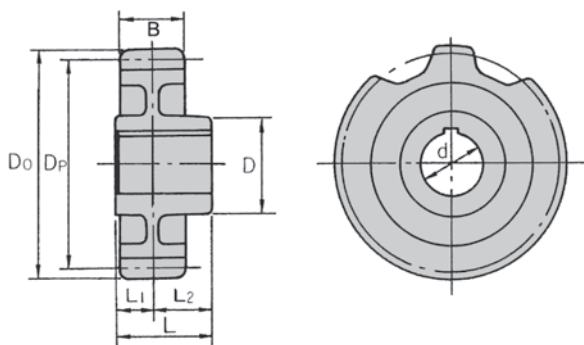

## Tail Drum

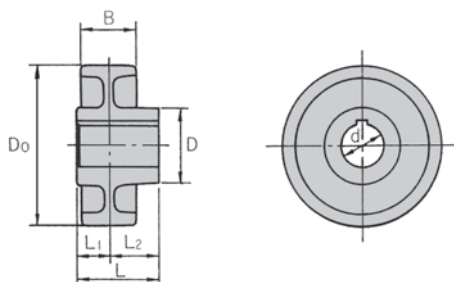

## Dimension Unit (mm) Hub Dia. Unit (mm)

Sprocket size	No. of teeth	Pitch dia Dp	Tip dia Do	Tooth width B	Axle dia. d		Sprocket size	Axle dia. d		Hub dia D	Hub width			
					over	under		over	under		L	L1	L2	
CC-250150-d	7	345.7	373	78	65	110	CC-250150-d	65	85	140	130	40	90	
	8	392.0	420		65	145		85	110		180	140	50	90
	9	438.6	466		65	145		110	145		225	170	70	100
	10	485.4	513		65	145		85	110		180	190	70	120
CC-350200-d	7	461.0	496	140	85	145	CC-350200-d	85	145	225	190	70	120	
	8	522.6	557		85	180		110	145		270	210	82	130
	9	584.8	619		85	180		145	180		270	210	80	130
CC-450250-d	7	576.2	628	160	110	180	CC-450250-d	110	145	225	210	80	130	
	8	653.3	705		110	180		140	180		270	210	80	130
	9	731.0	783		110	225		180	225		340	240	110	130
	10	809.0	861		110	225								

(Example of indication of Sprockets Number) CC-W250150 -8 No.d Sprocket Size No. of teeth Dimension of axle hole

## Dimension Unit (mm) Hub Dia. Unit (mm)

Sprocket size	No. of teeth	Equivalent pitch dia.	Tip dia Do	Tooth width B	Axle dia. d		Tail drum size	Axle dia. d		Hub dia D	Hub width			
					over	under		over	under		L	L1	L2	
CC-250150-t	7	345.7	304	78	65	110	CC-250150-t	65	85	140	130	40	90	
	8	392.0	350		65	110		85	110		180	140	50	90
	9	438.6	397		65	110		85	110		180	190	70	120
	10	485.4	444		65	110								
CC-350200-t	7	461.0	410	140	85	145	CC-350200-t	85	110	225	190	70	120	
	8	522.6	470		85	145		110	145		270	210	80	130
	9	584.8	533		85	145		110	145		270	210	80	130
CC-450250-t	7	576.2	500	160	85	145	CC-450250-t	85	110	225	210	80	130	
	8	653.3	577		85	145		110	145		270	210	80	130
	9	731.0	654		85	145								
	10	809.0	732		85	145								

(Example of indication of Sprockets Number) CC-W250150 -8 No.d Sprocket Size No. of teeth Dimension of axle hole



**Components for chain conveyors,  
scraper - conveyors, etc...  
Round link chain type**

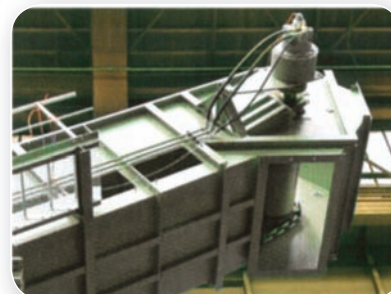
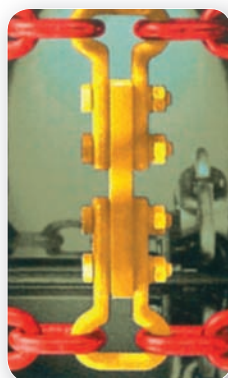
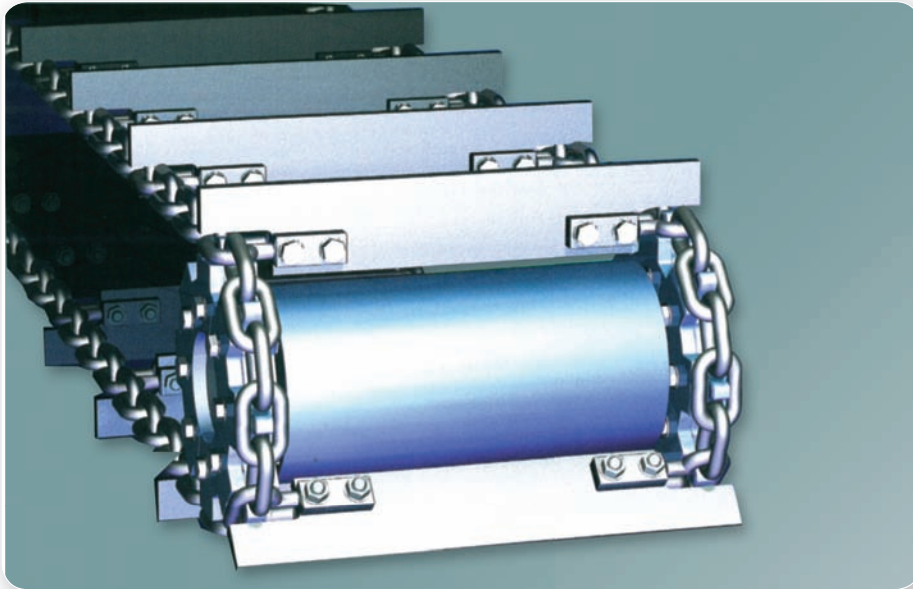

DROP FORGED



# Overview

## Scraper attachments options

### Description

### Type

Special scraper attachment type SP



Shackles type TS/type DIN 5699



Split scraper attachment type BG 22



Lift-in scraper bars type EFS



Plug-in scraper attachment  
Type SMG and SMO



Push-in scraper bars with safety pin  
Type EFL



Scraper attachment with welded  
Flange type AFS

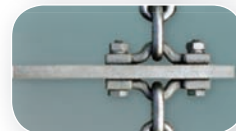
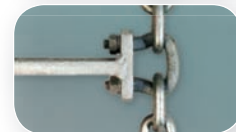
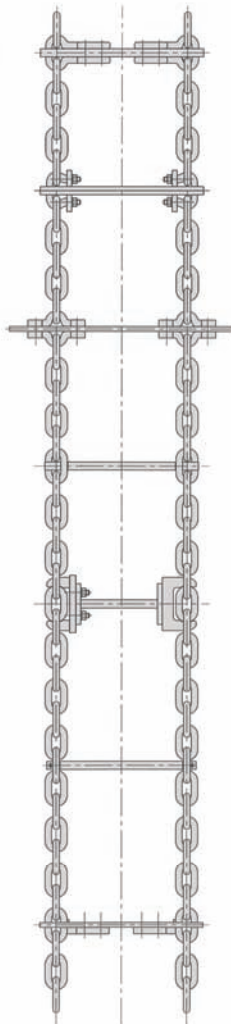

### Scraper attachment option

**GEHA-chains are utilised in the following chain conveyors: scraper conveyors, trough conveyors, forged link chain conveyors, disc conveyors and chain link mesh conveyors.**

**GEHA**-components for chain conveyors are successfully employed worldwide to solve conveyor problems. All **GEHA** products are perfectly matched for quality and compatibility. We constantly develop, in collaboration with clients, new solutions to keep up with increasing demands for cost effectiveness and improved safety. The principle industries served by **GEHA** include cement, lime, sugar, power, chemical, water treatment and farming. Typical applications for **GEHA** products include: bunker discharge conveyors, drag conveyors, wet de-ashers, cleaning scrapers, waste disposal, wood chip conveyors, etc.

**GEHA** is able to provide worldwide support during design, optimisation, erection and maintenance of conveyors.



DROP FORGED



# Dimensions and technical data for round link chains

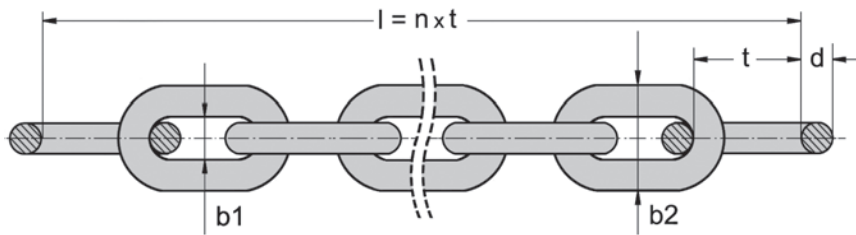

## Dimensions and qualities

## Dimensions for round link chains

Dimensions/ mm nominal dia. x pitch d x t (mm)	DIN chain	b1 Inside width min. (mm)	b2 Outside width max. (mm)	Weight kg/m	Tempered qualities			Case hardened qualities					
					GEHA 31	GEHA 32	GEHA 280 E	GEHA 21	GEHA 210 E	GEHA 400 E	GEHA 5	GEHA 350 E	
					MBK kN <sub>1</sub>	MBK kN <sub>1</sub>	MBK kN <sub>1</sub>	MBK kN <sub>1</sub>	MBK kN <sub>1</sub>	MBK kN <sub>1</sub>	MBK kN <sub>1</sub>	MBK kN <sub>1</sub>	
6 x 18,5	766	7,2	20,4	0,8	28	34	15	14	12	22	20	19	
8 x 22,5	WN	9,2	25,6	1,4	50	60	28	25	21	40	37	35	
8 x 24,0	766	9,6	27,2	1,4	50	60	28	25	21	40	37	35	
8 x 25,4	WN	10,0	26,0	1,4	50	60	28	25	21	40	37	35	
9 x 27,0	766	10,8	30,6	1,8	63	76	35	32	26	51	47	44	
9 x 31,0	WN	12,0	30,2	1,5	63	76	35	32	26	51	47	44	
10 x 28,0	766	12,0	36,0	2,3	78	94	44	39	33	63	58	55	
10 x 35,0	764	14,0	36,0	2,0	78	94	44	39	33	63	58	55	
10 x 50,0	762	14,0	36,0	1,8	78	94	44	39	33	63	58	55	
11 x 31,0	766	13,2	40,0	2,7	95	114	53	47	40	76	70	66	
13 x 36,0	766	15,6	47,0	3,9	132	159	74	66	56	106	98	93	
13 x 45,0	764	18,0	47,0	3,5	132	159	74	66	56	106	98	93	
13 x 65,0	762	18,2	46,8	3,1	132	159	74	66	56	106	98	93	
14 x 41,0	766	16,8	50,0	4,4	154	185	86	77	65	123	114	108	
14 x 50,0	WN	16,3	47,0	4,1	154	185	86	77	65	123	114	108	
14 x 64,0	WN	16,3	47,0	3,7	154	185	86	77	65	123	114	108	
14 x 100,0	WN	16,0	47,0	3,0	154	185	86	77	65	123	114	108	
16 x 45,0	766	19,2	58,0	5,8	201	241	112	100	84	160	148	140	
16 x 56,0	764	22,0	58,0	5,2	201	241	112	100	84	160	148	140	
16 x 64,0	WN	20,0	55,0	5,1	201	241	112	100	84	160	148	140	
16 x 80,0	762	22,4	57,6	4,7	201	241	112	100	84	160	148	140	
18 x 50,0	766	21,6	65,0	7,4	254	305	142	127	107	203	188	178	
18 x 63,0	764	24,0	65,0	6,5	254	305	142	127	107	204	188	178	
18 x 64,0	WN	21,0	60,0	6,6	254	305	142	127	107	204	188	178	
19 x 75,0	WN	22,0	63,0	7,6	283	340	158	141	119	227	210	198	
20 x 56,0	766	24,0	72,0	9,0	314	376	175	157	132	251	232	220	
20 x 70,0	764	27,0	72,0	8,2	314	376	175	157	132	251	232	220	
20 x 100,0	762	28,0	72,0	7,4	314	376	175	157	132	251	232	220	
22 x 86,0	WN	26,0	74,0	9,8	380	456	212	190	160	304	281	266	
23 x 64,0	766	27,6	83,0	12,0	415	498	232	207	174	332	307	290	
23 x 80,0	764	31,0	83,0	11,0	415	498	232	207	174	332	307	290	
26 x 73,0	766	31,2	94,0	15,0	530	637	298	265	223	425	392	371	
26 x 91,0	764	35,0	94,0	14,0	530	637	298	265	223	425	392	371	
26 x 100,0	WN	31,0	87,0	13,5	530	637	298	265	223	425	392	371	
28 x 78,0	766	33,6	101,0	18,0	615	739	344	308	258	492	455	431	
28 x 98,0	764	36,0	101,0	16,5	615	739	344	308	258	492	455	431	
30 x 84,0	766	36,0	108,0	20,0	706	848	395	353	296	565	523	494	
30 x 105,0	764	39,0	108,0	19,0	706	848	395	353	296	565	523	494	
30 x 120,0	WN	36,0	102,0	17,8	706	848	395	353	296	565	523	494	
33 x 92,0	766	43,0	119,0	25,0	855	1026	478	427	359	684	633	598	
33 x 115,0	764	43,0	119,0	22,5	855	1026	478	427	359	684	633	598	
34 x 136,0	WN	39,0	113,0	23,8	907	1089	508	453	381	726	672	635	
36 x 101,0	766	43,2	130,0	29,0	1017	1221	570	508	428	814	753	712	
36 x 126,0	764	47,0	130,0	26,5	1017	1221	570	508	428	814	753	712	
38 x 44,0	WN	44,0	127,0	30,0	1134	1360	635	567	476	907	839	794	
39 x 109,0	766	51,0	140,0	34,0	1194	1433	669	597	502	956	884	836	
39 x 136,0	764	51,0	140,0	31,0	1194	1433	669	597	502	956	884	836	
42 x 118,0	766	50,0	151,0	40,0	1385	1662	776	692	582	1108	1025	970	
42 x 147,0	764	55,0	151,0	36,0	1385	1662	776	692	582	1108	1025	970	

MBK = min. breaking load, WN = works standard, other dimensions and qualities on request, including stainless steel and other alloy steels. 1) tolerance table 1

DROP FORGED



## Special scraper attachment type SP

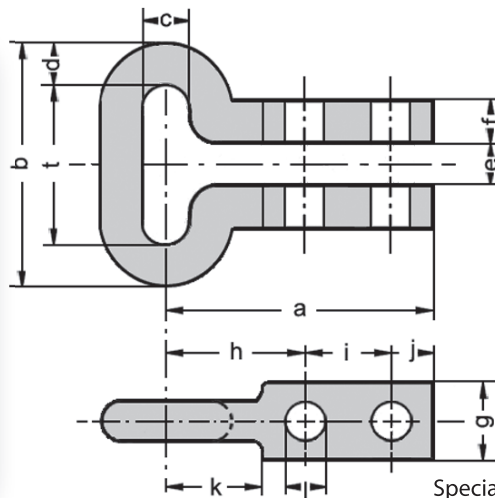

Special scraper attachment type SP

**Special scraper attachments type SP are supplied to suit chain to DIN or other standards.**

- suitable for horizontal and inclined conveyors
- conveying in upper or lower trough
- simple and economic scraper attachment

Special scraper attachments are suitable for use with single- and twin-strand conveyors. They can be fitted to conveyors with wheels having projecting teeth, pocket teeth or toothless wheels. Scraper centres can be varied by means of the number of chain links fitted. Supply can be either loose or pre-assembled with the attachments and scraper bars. We recommend the use of high tensile bolts for attaching the scraper, grade 8.8 minimum. Chains which have lengthened as a result of wear can be

shortened by unbolting one scraper and removal of one (set) chain length and attachment.

Individual chain links can be removed by cold cutting of the link. Both tempered and case hardened attachments are part of a standard manufacturing programme. The quality of the attachments is matched with the chain quality. All necessary fittings as well as suitable scraper bars, standard or bespoke, can be furnished.

### Special scraper bar attachments for chains to DIN or works standard

To suit chain, nominal diameter x pitch d x t/mm	Chain DIN	Drawing number	Dimensions / mm													Bolts/nuts			Weight kg/ each	Qualities <sup>*)</sup> , MBK (kN)				
			a	b	c	e	f	g	h	i	j	k	l	Tempered GEHA						Hardened contact areas GEHA				
			31	32	41	5	42																	
10 x 35	764	1765	82	55	14	12	10	22	40	30	12	30	8,5	M 8	x	45	0,25	78	94	44	58	63		
13 x 45	764	1765	100	71	18	15	12	28	50	35	15	34	12,5	M 12	x	55	0,50	132	159	74	98	106		
14 x 50	WN	2164 1	104	78	17	16	13	33	58	30	16	36	13,0	M 12	x	60	0,60	154	185	77	114	123		
16 x 56	764	1765	130	88	18	20	16	32	70	40	20	50	17,0	M 16	x	75	0,90	201	241	112	148	160		
16 x 64	WN	4282	130	96	20	20	16	32	70	40	20	50	13,0	M 12	x	70	1,00	201	241	100	148	160		
18 x 63	764	1765	125	99	24	19	20	35	65	40	20	45	17,0	M 16	x	80	1,15	254	305	127	188	203		
18 x 64	WN	1081 B	125	100	24	19	20	35	65	40	20	45	17,0	M 16	x	80	1,15	254	305	127	188	203		
19 x 75	WN	3169 A	125	113	23	20	20	35	65	40	20	45	17,0	M 16	x	80	1,20	283	340	141	210	227		
20 x 56	766	1765	145	96	25	22	20	30	85	40	20	65	17,0	M 16	x	90	1,25	314	376	157	232	251		
20 x 70	764	1765	145	110	27	22	20	35	85	40	20	65	17,0	M 16	x	90	1,30	314	376	157	232	251		
20 x 80	WN	3167 A	124	120	23	22	20	40	68	35	21	54	18,0	M 16	x	90	1,50	314	376	157	232	251		
22 x 86	WN	3983	140	132	26	25	20	50	80	40	20	62	18,0	M 16	x	90	1,90	380	456	190	281	304		
23 x 80	764	1765	164	126	31	24	20	42	89	50	25	63	21,0	M 20	x	90	2,00	415	498	232	307	332		
23 x 100	WN	2151	137	146	30	24	20	48	78	40	19	60	18,0	M 16	x	90	2,15	415	498	207	307	332		
26 x 91	764	1765	170	143	35	31	22	45	95	50	25	65	21,0	M 20	x	100	2,90	530	637	297	392	424		

<sup>\*)</sup> stated values refer to use of bolts and nuts grade 8.8, WN = works standard, MBK = min. breaking load.

DROP FORGED



# Chain shackle type TS and DIN 5699

Shackles are fastened to the scraper bar by two nuts and a securing element. Shackle and scraper bar form a stable, simple form of connection. A wide range of sizes and qualities is available to suit most applications.

We recommend our shackle type TS for higher demands as the lip on the distance plate provides support on the wheel rim. In addition the TS-shackle permits a much higher breaking load compared to the DIN-shackle. TS-shackles can be used

with wheels having projecting teeth and pocket teeth. Plain wheels can be used as return idlers.

## Shackle type TS

- Supplied also pre-assembled with the chain to endless chain strands
- Highest services achieved through the reliability of the secured TS-distance plate

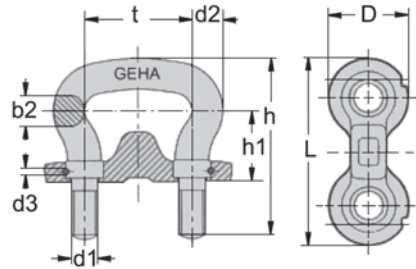

## Dimensions and qualities of shackles - type TS

pitch t/mm	to suit chain, nominal diameter x pitch / DIN		weight kg/each complete	dimensions / mm							qualities tempered GEHA 32 MBK (kN)	hardened contact areas GEHA 6 MBK (kN)			
				b2	d2	d3	d1	h	h1	D			L	I	
45	13	x 45	/ 764	0,35	14	14	5	M 12	64,5	40,5	37	75	26	159	119
56	16	x 56	/ 764	0,70	16	16	5	M 14	68	40	45	95	28	241	180
63	18	x 63	/ 764	1,00	18	18	5	M 16	74	43	50	110	34	305	228
70	20	x 70	/ 764	1,45	20	20	5	M 20	83	48	55	120	37	376	280
80	23	x 80	/ 764	1,85	23	23	5	M 20	92	53	60	130	37	498	360
91	26	x 91	/ 764	2,70	26	26	6	M 24	104	60	70	155	42	636	477
105	30	x 105	/ 764	3,90	30	30	6	M 24	118	68	80	165	42	847	635
126	36	x 126	/ 764	6,10	35	35	8	M 30	139	81	85	200	66	1220	915
136	39	x 136	/ 764	7,60	39	38	8	M 36	152	88	90	220	79	1432	1074
147	42	x 147	/ 764	9,00	40	40	8	M 36	162	93	95	230	79	1661	1188

Tolerance: table 1, MBK = min. breaking load

## Shackle to DIN 5699

- Simple to fit
- Dimensions to suit chain to DIN 764

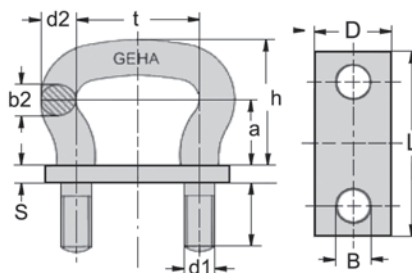

## Dimensions and qualities of shackles - DIN 5699

Scraper connected by shackle to DIN 5699

pitch t/mm	to suit chain, nominal diameter x pitch / DIN		weight kg/each complete	chain shackle dimensions / mm						distance plate dimensions in mm				qualities tempered		hardened contact areas		
				b2	d2	d1	h	a	l	L	D	S	B	GEHA 31 MBK (kN)	GEHA 32 MBK (kN)	GEHA 41 MBK (kN)	GEHA 5 MBK (kN)	
35	10	x 35	/ 764	0,21	10	12	M 10	43	23	13	65	30	12	10,5	78	94	54	68
45	13	x 45	/ 764	0,34	13	15	M 12	53	28	18	75	30	12	13	132	159	88	110
56	16	x 56	/ 764	0,59	16	18	M 14	64	34	23	95	40	12	15	201	241	129	162
63	18	x 63	/ 764	0,58	18	21	M 26	71	37	25	110	40	15	17	254	305	170	213
70	20	x 70	/ 764	1,25	20	23	M 20	80	42	30	120	50	15	21	314	376	207	259
80	23	x 80	/ 764	1,50	23	26	M 20	89	47	30	130	50	15	21	415	498	269	337
91	26	x 91	/ 764	2,36	26	29	M 24	99	52	35	150	60	20	25	530	637	339	424
105	30	x 105	/ 764	3,06	30	34	M 24	114	60	35	165	60	20	25	706	848	458	574
126	36	x 126	/ 764	5,40	36	40	M 30	134	71	45	200	70	20	31	1017	1221	646	810
136	39	x 136	/ 764	7,81	39	44	M 36	146	76	50	220	80	25	37	1194	1433	771	950
147	42	x 147	/ 764	8,83	42	47	M 36	157	81	50	230	80	25	37	1385	1622	887	1110

Other shackles to DIN 745 or out of DIN available, tolerance: table 1, MBK = min. breaking load

DROP FORGED





## Plug - in scraper bar attachments type SMG and SMO

### Plug-in attachment

- Fast connection to endless chain strands
- Different scraper bar centres possible
- Reversible conveying possible
- Hight service life even under extreme conditions
- Fitted to loose chain

The attachments are manufactured from manganese-chrome-alloy steel and are case hardened.

The connectors can easily be welded to mild steel and low alloy steel. The following are suitable welding alloys: MAG: DIN 8559/SG3; E: DIN 1913 E 5154 B10 or equal.

DROP FORGED

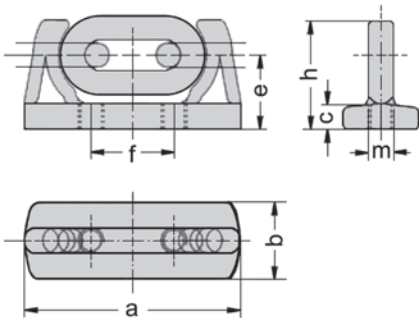

Plug-in attachments SMG

Plug-in attachments SMG are drop forged in one-piece with the base plate. The attachments are manufactured from manganese-chrome-alloy steel and are completely case hardened. Connection of the attachment with the scraper is by use of bolts grade 8.8.

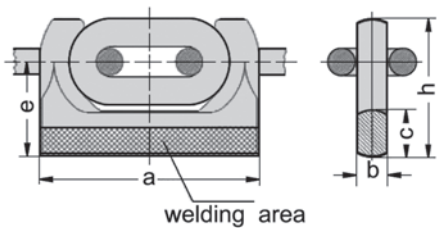

Plug-in attachments SMO

Plug-in attachments SMO are drop forged and are used without base plate. They are suitable for welding directly to the scraper bar. The attachments are manufactured from manganese-chrome-alloy steel and are completely case hardened.



### Plug-in attachments type SMG, forged with base plate

### Plug-in attachments type SMO forged without base plate

Plug-in attachment type	to suit chain, nominal Diameter x Pitch, d x t/mm	weight kg/each	dimensions/mm						
			a	b	c	e	f	m	h
SMG	14 x 50	0,7	112	40	12	38	45	(M 12)	57
SMO		0,5	110	16	25	50			73
SMG	16 x 64	1,2	145	50	15	48	52	(M 16)	76
SMO		0,8	135	19	30	59			83
SMG	19 x 75	2,0	170	60	20	58	65	(M 20)	85
SMO		1,2	156	21	36	69			100
SMG	22 x 86	3,0	195	70	20	68	71	(M 20)	100
SMO		2,0	182	25	40	80			115
SMG	26 x 100	4,5	230	80	20	72	85	(M 20)	110
SMO		3,3	214	30	45	92			135
SMG	30 x 120	6,7	270	90	25	85	98	(M 24)	130
SMO		5,3	252	35	55	110			160
SMG	34 x 136	10,0	310	100	30	98	110	(M 27)	150
SMO		7,2	282	38	60	122			177

Other dimensions and qualities on request. Dimensions ( ) apply only for attachments with threads.



## Scraper attachments for endless chain

### Arrangements of replaceable, bolted and welded attachments for endless chain.

In addition to using chain ends and special attachments for conveyors, endless chain can also be used. Such an arrangement has the advantage of allowing different scraper bar centres to be used. In addition, the transport unit can be tailored to individual applications.

Below are some examples of attachments for use with endless chain strands. Other, bespoke attachments can be provided to suit the users' application.

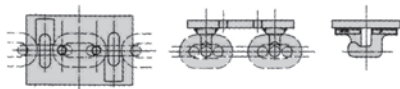

Individually welded attachments for use with wheels with projecting teeth, forged and case hardened.

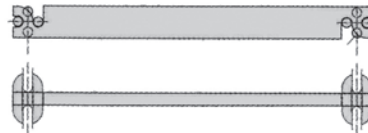

Lift-in scraper bars for use with pocket toothed wheels.

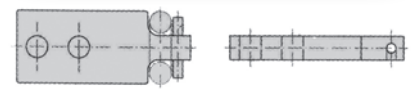

Plug-in attachments type EFL with security pin.

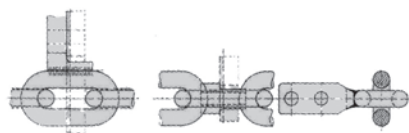

Welded attachments type AFS for pocket and projected toothed wheels for bolting scraper and use in single and twin strand conveyors.

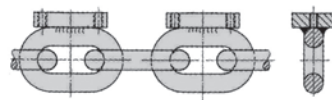

Welded attachment for use in abattoir.

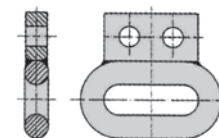

Welded attachment for different transport units.

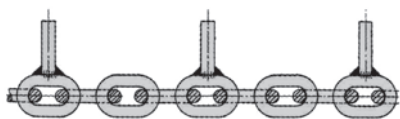

Transport unit for loose products, i.e. household waste.

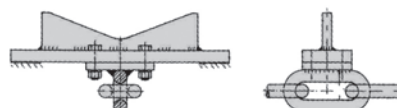

Transport unit for forestry products.

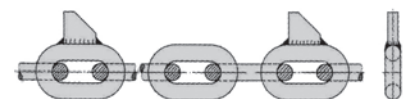

Lower trough transport for wagons.

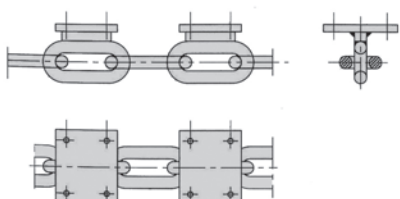

Plate conveyor used as open assembly conveyor for tools, etc.

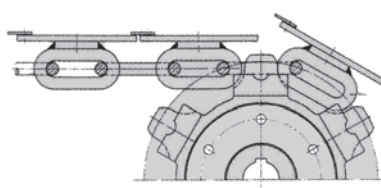
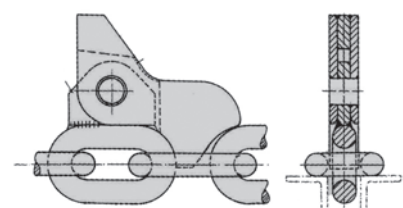

Plate belt conveyor.



Reversible transport catch.

DROP FORGED



# Chain locks

## Chain lock type A

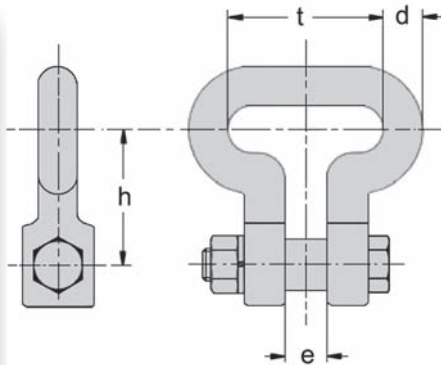

Chain locks type A are drop forged, tempered and inductively hardened in the contact areas to improve wear resistance. They are supplied complete with hexagon bolts to DIN 931, grade 8.8. These chain locks are suitable for use with wheels with pocket teeth and projecting teeth. Normally these chain locks are installed horizontally, but special designs also allow vertical installation. Their material quality is matched with that of the chain.

DROP FORGED

## Sizes and qualities of GEHA chain locks type A

to suit chain, nominal diameter x pitch d x t/mm	DIN chain	dimensions/mm		weight kg/each	hexagon bolt DIN 931 8.8	qualities, MBK (kN) <sup>1</sup> tempered qualities		hardened contact area qualities		
		e	h			GEHA 31	GEHA 32	GEHA 41	GEHA 5	GEHA 42
						MBK (kN)	MBK (kN)	MBK (kN)	MBK (kN)	MBK (kN)
10 x 35	764	12	40	0,25	M 10	78	94	44	58	63
13 x 45	764	15	50	0,45	M 12	132	159	74	98	106
14 x 50	WN	16	58	0,50	M 12	154	185	77	114	123
16 x 56	764	20	70	0,85	M 16	201	241	112	148	160
16 x 64	WN	20	70	0,95	M 16	201	241	100	148	160
18 x 63	764	19	65	1,10	M 16	254	305	127	188	203
18 x 64	WN	19	65	1,10	M 16	254	305	127	188	202
19 x 75	WN	20	65	1,20	M 16	283	340	141	210	227
20 x 56	766	22	85	1,20	M 20	314	376	157	232	251
20 x 70	764	22	85	1,30	M 20	314	376	157	232	251
20 x 80	WN	22	68	1,40	M 20	314	376	157	232	251
22 x 86	WN	25	80	1,80	M 20	380	456	190	281	304
23 x 80	764	24	89	1,80	M 20	415	498	207	307	332
23 x 100	WN	24	78	1,90	M 20	415	498	207	307	332
26 x 91	764	31	95	2,50	M 20	530	637	297	392	424

Other dimensions and qualities on request. WN = works standard, tolerance -10%, 32/400E -20%, MBK = min. break load.

## Chain lock type F

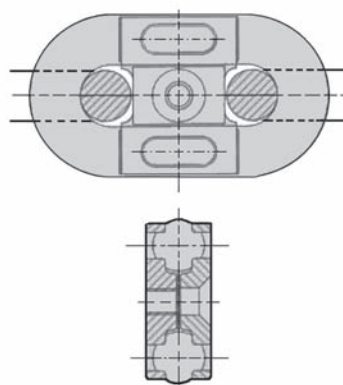

Chain locks type F are used for connecting longer chain strands. These chain locks have the same physical properties to that of the corresponding chain. Assembly of the five components is simple as the chain only needs to be slackened slightly. These chain locks should only be installed vertically. Dimensions are to suit the corresponding chain.



## Chain lock type C

### Chain lock type C

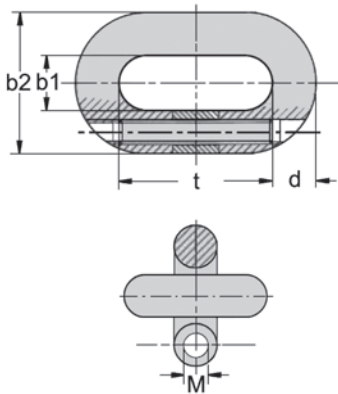

Chain locks type C are suitable for use horizontally and vertically with wheels with pocket teeth and projecting teeth. The grub screw (with internal hexagon) is supported by a spacer sleeve. These chain locks are supplied both in tempered and hardened finish. Dimensions are completely compatible with the corresponding chain. These chain locks should be installed vertically only to minimise bending and premature fatigue failure.

### Sizes and qualities of GEHA chain locks type C

to suit chain, nominal diameter x pitch <i>d x t/mm</i>	DIN chain	dimensions mm		weight kg/each	grub screw (with internal hexagon) <i>M</i>	qualities, MBK (kN) <sup>1</sup>		case hardened GEHA qualities						
		inside width <i>b1</i>	outside width <i>b2</i>			tempered qualities								
8 x 24	766	9,6	27,2	0,05	M 5 x 25	37	45	280 E	21	18	15	30	27	26
8 x 25,4	WN	10	26	0,05	M 5 x 30	37	45	21	18	15	30	27	26	
9 x 27	766	10,8	30,6	0,06	M 5 x 30	47	57	26	24	19	38	35	33	
10 x 35	764	14	36	0,07	M 6 x 35	58	70	33	29	24	47	43	41	
10 x 50	762	14	36	0,09	M 6 x 50	58	70	33	29	24	47	43	41	
11 x 31	766	13,2	40	0,09	M 6 x 35	71	85	39	35	30	57	52	49	
13 x 45	764	18	47	0,16	M 8 x 40	99	119	55	49	42	79	73	69	
14 x 50	WN	16,3	47	0,21	M 8 x 50	115	138	64	57	48	92	85	81	
16 x 56	764	22	58	0,30	M 10 x 55	150	180	84	75	63	120	111	105	
16 x 64	WN	20	55	0,34	M 10 x 60	150	180	84	75	63	120	111	105	
16 x 80	762	22,4	57,6	0,38	M 10 x 80	150	180	84	75	63	120	111	105	
18 x 63	764	24	65	0,41	M 10 x 60	190	228	106	95	80	153	141	133	

Other dimensions and qualities on request. 1) Tolerance -20%, WN = works standard, tolerance -10%, 32 -20%, MBK = min. breaking load.

### Chain lock type FL/RS

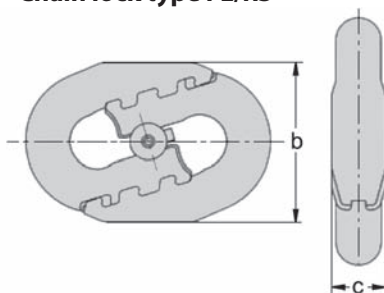

to suit chain, nominal diameter x pitch <i>d x t/mm</i>	dimensions/mm height <i>b</i>	width <i>c</i>	weight kg/each	type <i>M</i>
16 x 64	56	18,5	0,50	RS
19 x 75	66,5	23	0,80	RS
22 x 86	77	26	1,90	FL
26 x 100	89	29	2,40	FL
30 x 120	107	36	3,20	FL
34 x 136	117	40	4,20	FL
38 x 144	133	45	5,20	FL

Chain locks type FL are used for connecting longer chain strands. These chain locks have the same physical properties to that of the corresponding chain. Assembly of the five components is simple as the chain only needs to be slackened slightly. These chain locks should only be installed vertically. Dimensions are to suit the corresponding chain.

DROP FORGED



## Chain wheels with projecting teeth, steel, replaceable toothed rim, type VIA and VIE-C

DROP FORGED

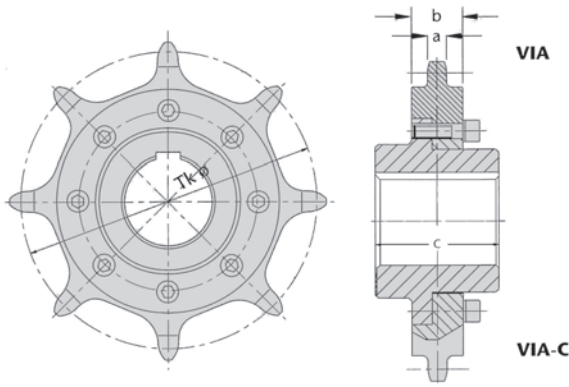

Chain wheel with projecting teeth, replaceable steel rim, type VIA or VIE-C with chamfered teeth and drop-outs.



Sizes of GEHA chain wheels, projecting teeth, steel, replaceable rim, type VIA/VIE-C

type VIA/VIE-C pitch circle diameter mm, Tk Ø	to suit chain, nominal dia- meter x pitch, d x t/mm	DIN	number of teeth	dimension/mm			weight kg/each
				a	b	c	
179	10 x 35	764	8	11,5	34	60	4
202	10 x 35	764	9	11,5	34	60	7
224	10 x 35	764	10	11,5	34	60	8
231	13 x 45	764	8	15	45	100	10
259	13 x 45	764	9	15	45	100	16
288	13 x 45	764	10	15	45	100	18
256	14 x 50	WN/22252	8	15	45	100	16
288	14 x 50	WN/22252	9	15	45	100	16
320	14 x 50	WN/22252	10	15	45	100	22
287	16 x 56	764	8	18	50	100	18
323	16 x 56	764	9	18	50	100	25
247	16 x 64	WN	6	18	50	100	14
328	16 x 64	WN	8	18	50	100	28
369	16 x 64	WN	9	18	50	100	32
409	16 x 64	WN	10	18	50	100	38
243	18 x 63	764	6	20	55	120	10
283	18 x 63	764	7	20	55	120	17
323	18 x 63	764	8	20	55	120	22
363	18 x 63	764	9	20	55	120	31
384	19 x 75	WN/22252	8	20	60	140	28
479	19 x 75	WN/22252	10	20	60	140	41
574	19 x 75	WN/22252	12	20	60	140	56
315	20 x 70	764	7	23	60	140	27
359	20 x 70	764	8	23	60	140	38
403	20 x 70	764	9	23	60	140	50
332	22 x 86	WN/22252	6	23	69	140	35
386	22 x 86	WN/22252	7	23	69	140	45
441	22 x 86	WN/22252	8	23	69	140	55
550	22 x 86	WN/22252	10	23	69	140	80

Other dimensions and qualities on request, WN = works standard

### Chain wheels, with projecting teeth and replaceable rims

- Wheels for chains to DIN and other standards
- Hubs from mild steel with CrMo steel rim

GEHA chain wheels type VIA provide two primary advantages: they achieve a high service life; they are simple and easy to fit and thus reduce the cost of replacement. The wheels with projecting teeth and replaceable rims are recommended for chain pitches  $\geq 3.5 \times d$ . The chain contact surfaces are hardened to minimise wear. As the teeth push through the link, a self-cleaning effect results which also prevents a build-up between chain and wheel. Teeth are also supplied chamfered, on request, for applications with sticky materials. Replaceable segments have the advantage that they can be exchanged without removing the hub which results in reduced downtime. GEHA chain wheels type VIA are suitable for special attachments, horizontal shackles to DIN, TS-shackle and push-in scraper bars. Wheel dimensions can also be tailored to suit existing installations.



## Chain wheels with projecting teeth, steel, replaceable toothed rim, type GIA

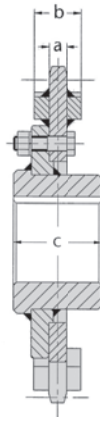
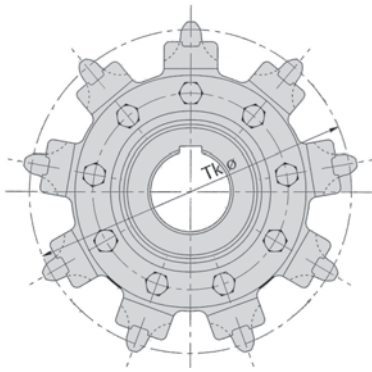

Chain wheel type GIA, projecting teeth, replaceable toothed rim with welded chain support.



DROP FORGED

Sizes of GEHA chain wheels, projecting teeth, replaceable toothed rim,

type GIA pitch circle diameter mm, Tk Ø	to suit chain, nominal diameter x pitch, d x t/mm	DIN	number of teeth	dimension/mm			weight kg/each
				a	b	c	
231	13 x 45	764	8	15	45	100	10
259	13 x 45	764	9	15	45	100	12
288	13 x 45	764	10	15	45	100	14
256	14 x 50	WN/22252	8	15	45	100	14
288	14 x 50	WN/22252	9	15	45	100	15
320	14 x 50	WN/22252	10	15	45	100	19
216	16 x 56	764	6	18	54	100	15
252	16 x 56	764	7	18	54	100	16
287	16 x 56	764	8	18	54	100	18
323	16 x 56	764	9	18	54	100	22
247	16 x 64	WN	6	18	54	100	17
328	16 x 64	WN	8	18	54	100	19
369	16 x 64	WN	9	18	54	100	29
409	16 x 64	WN	10	18	54	100	32
243	18 x 63	764	6	20	60	120	18
283	18 x 63	764	7	20	60	120	20
323	18 x 63	764	8	20	60	120	25
363	18 x 63	764	9	20	60	120	29
290	19 x 75	WN/22252	6	20	60	140	19
384	19 x 75	WN/22252	8	20	60	140	32
479	19 x 75	WN/22252	10	20	60	140	52
574	19 x 75	WN/22252	12	20	60	140	77
315	20 x 70	764	7	23	63	140	22
359	20 x 70	764	8	23	63	140	29
403	20 x 70	764	9	23	63	140	36
332	22 x 86	WN/22252	6	25	71	140	29
386	22 x 86	WN/22252	7	25	71	140	41
441	22 x 86	WN/22252	8	25	71	140	52
550	22 x 86	WN/22252	10	25	71	140	55
410	23 x 80	764	8	27	73	160	51
461	23 x 80	764	9	27	73	160	72
466	26 x 91	764	8	30	80	180	75
524	26 x 91	764	9	30	80	180	80
582	26 x 100	764	10	30	80	180	90
513	26 x 100	WN	8	30	80	180	120
576	26 x 100	WN	9	30	80	180	135

Other dimensions and qualities on request, WN = works standard

- Suitable as drive wheels for medium duty applications
- Excellent service life due to hardened contact surfaces

GEHA manufactures chain wheels with projecting teeth, type GIA for chains above 13mm and use with special attachments and horizontal shackles to DIN or TS shackles. The projecting teeth clean the chain links effectively which prevents a build-up of material between chain and wheel. Long service lives are achieved through hardening of the teeth. Replacement time is minimised as the hub can remain in place thus reducing maintenance cost as are the cost of new toothed rims.

GEHA also supplies special wheels type GIA with chamfered drop-out pockets for use with cohesive products. Wheels for existing installation are provided with dimensions to suit clients' requirements.



## Chain wheels with pocket teeth, steel, replaceable rims, type GTA

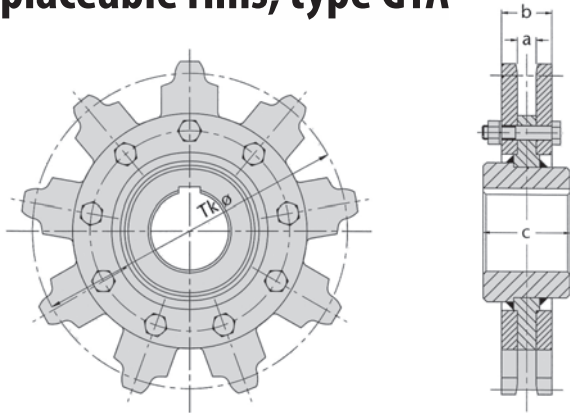

Sizes of chain wheels, pocket teeth, replaceable rims, type GTA

pitch circle diameter mm, Tk Ø	to suit chain, nominal diameter x pitch, d x t/mm	DIN	number of teeth	dimension/mm			weight kg/each
				a	b	c	
135	10 x 35	764	6	14	38	80	4
157	10 x 35	764	7	14	38	80	7
179	10 x 35	764	8	14	38	80	8
202	10 x 35	764	9	14	38	80	9
231	13 x 45	764	8	18	48	100	10
259	13 x 45	764	9	18	48	100	13
288	13 x 45	764	10	18	48	100	19
256	14 x 50	WN/22252	8	18	48	100	15
288	14 x 50	WN/22252	9	18	48	100	22
320	14 x 50	WN/22252	10	18	48	100	24
216	16 x 56	764	6	21	57	100	13
252	16 x 56	764	7	21	57	100	17
287	16 x 56	764	8	21	57	100	21
323	16 x 56	764	9	21	57	100	32
358	16 x 56	764	10	21	57	100	38
247	16 x 64	WN	6	21	57	100	23
328	16 x 64	WN	8	21	57	100	31
369	16 x 64	WN	9	21	57	100	33
409	16 x 64	WN	10	21	57	100	39
243	18 x 63	764	6	23	63	120	17
283	18 x 63	764	7	23	63	120	27
323	18 x 63	764	8	23	63	120	30
363	18 x 63	764	9	23	63	120	38
403	18 x 63	764	10	23	63	120	45
290	19 x 75	WN/22252	6	23	63	140	25
384	19 x 75	WN/22252	8	23	63	140	40
479	19 x 75	WN/22252	10	23	63	140	47
574	19 x 75	WN/22252	12	23	63	140	55
315	20 x 70	764	7	25	65	140	28
359	20 x 70	764	8	25	65	140	38
403	20 x 70	764	9	25	65	140	47
332	22 x 86	WN/22252	6	27	73	140	43
386	22 x 86	WN/22252	7	27	73	140	45
441	22 x 86	WN/22252	8	27	73	140	55
550	22 x 86	WN/22252	10	27	73	140	65
410	23 x 80	764	8	28	78	140	60
461	23 x 80	764	9	28	78	140	67
466	26 x 91	764	8	32	82	160	85
524	26 x 91	764	9	32	82	160	105
671	30 x 105	764	10	36	96	200	220
726	36 x 126	764	9	42	112	220	242

Other dimensions and qualities on request, WN = works standard

- Suitable as drive wheels
- Excellent service life due to hardened contact surfaces

GEHA's pocket teeth chain wheels have an excellent service life. The toothed rims are manufactured from special alloy steel. Chain contact surfaces are machined and sides are chamfered to ensure a good contact with the chain and a good lead into the wheel. Chain contact surfaces are hardened to ensure a good service life.

Pocket toothed chain wheels type GTA are supplied for use with special attachments, vertical shackle to DIN or TS-shackle and lift-in scraper bars. Replaceable rims have the advantage that the hub can be left in place during refurbishment, which also saves time and cost. Purchasing cost for replacements are also reduced compared to completely new wheels. Dimensions for existing installations are tailored to suit the application.



## Chain wheels with pocket teeth, cast steel, one-piece, type GSE

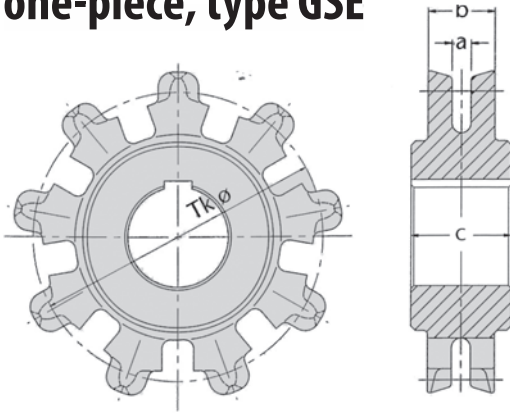

Chain wheel type GSE, one-piece, pocket teeth, cast steel



DROP FORGED

Sizes of chain wheels, pocket teeth, one-piece, type GSE

pitch circle diameter mm, Tk Ø	to suit chain, nominal diameter x pitch, d x t/mm	DIN	drawing number	number of teeth	dimension/mm			weight kg/each
					a	b	c	
179	10 x 35	764	KR 2443	8	12,5	53	60	8
259	13 x 45	764	KR 4073	9	17	65	90	22
345	13 x 45	764	KR 2350	12	17	63	100	30
243	18 x 63	764	KR 1806	6	22	80	100	24
283	18 x 63	764	KR 1826	7	22	68	90	27
323	18 x 63	764	KR 2028	8	22	80	100	36
363	18 x 63	764	KR 2290	9	22	78	100	41

Other dimensions and qualities on request.

GEHA chain wheels manufactured of cast steel offer an inexpensive solution as drive and idling wheels for scraper conveyors.

Chain contact surfaces are case hardened to increase the service life. We recommend the use of GEHA chain wheels manufactured from alloy steel for heavy duty applications.

## Support idlers and snub wheels type VUE, GUE, GGE

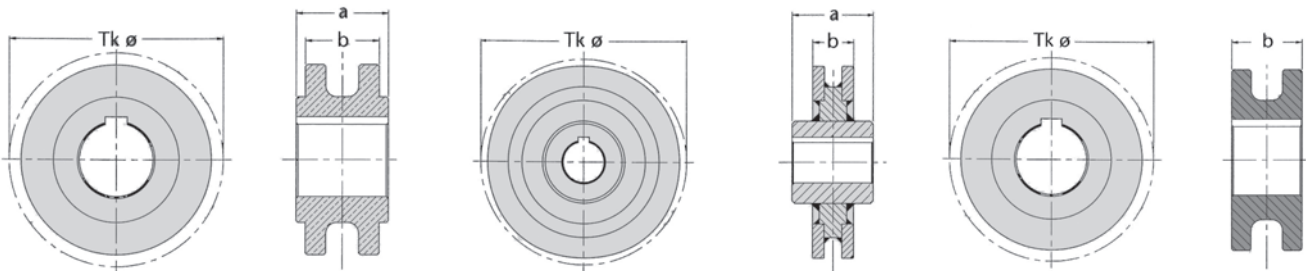

Support idling wheel type VUE, machined from steel

Support idling wheel type GUE, welded steel design

Support idling wheel type GGE, in cast iron

Size of support idling wheels in cast iron or steel, welded or machined, type VUE, GUE and GGE

pitch circle diameter mm, Tk Ø	to suit chain, nominal diameter x pitch, d x t/mm	dimensions/mm		weight kg/each
		a	b	
120	10	60	40	4
146	13	70	48	6
162	16	80	50	7
240	18	90	53	14
260	20	100	60	26
309	23	100	80	41
352	26	110	90	52
340	30	120	105	55
408	36	140	125	80

Other dimensions and qualities on request.

GEHA-support idling wheels and snub wheels are alternative solutions to guide rails for horizontal and inclined conveyors. Use of wheels reduces friction and thus power requirements. The following types are available:

- GEHA type VUE or GUE in steel, fabricated by welding or machined from a blank. Wheels with hub length above 65 mm are supplied welded.
- GEHA type GGE in cast iron.





# Chain wheels, toothless, steel, type GUA and type GUE

Sizes of GEHA chain wheels, toothless, type GUA and type GUE

pitch circle diameter mm, Tk Ø	to suit chain, nominal diameter x pitch, d x t/mm	DIN	dimension/mm			weight kg/each
			a	b	c	
144	10 x 28	766	14	38	60	4
161	10 x 28	766	14	38	60	4
179	10 x 28	766	14	38	60	5
215	10 x 28	766	14	38	60	6
135	10 x 35	764	14	38	60	4
157	10 x 35	764	14	38	60	4
179	10 x 35	764	14	38	60	5
202	10 x 35	764	14	38	60	6
224	10 x 35	764	14	38	60	9
268	10 x 35	764	14	38	60	13
185	13 x 36	766	18	48	80	5
207	13 x 36	766	18	48	80	7
230	13 x 36	766	18	48	80	9
231	13 x 45	764	18	48	100	10
259	13 x 45	764	18	48	100	12
288	13 x 45	764	18	48	100	14
256	14 x 50	WN/22252	19	49	100	13
288	14 x 50	WN/22252	19	49	100	18
320	14 x 50	WN/22252	19	49	100	22
174	16 x 45	766	21	57	100	6
202	16 x 45	766	21	57	100	8
231	16 x 45	766	21	57	100	9
259	16 x 45	766	21	57	100	10
288	16 x 45	766	21	57	100	13
216	16 x 56	764	21	57	100	7
252	16 x 56	764	21	57	100	10
287	16 x 56	764	21	57	100	13
323	16 x 56	764	21	57	100	17
358	16 x 56	764	21	57	100	26
247	16 x 64	WN/22252	21	57	100	10
328	16 x 64	WN/22252	21	57	100	17
369	16 x 64	WN/22252	21	57	100	24
409	16 x 64	WN/22252	21	57	100	28
256	18 x 50	766	23	63	120	13
288	18 x 50	766	23	63	120	16
320	18 x 50	766	23	63	120	18
243	18 x 63	764	23	63	120	11
283	18 x 63	764	23	63	120	14
323	18 x 63	764	23	63	120	17
363	18 x 63	764	23	63	120	22
403	18 x 63	764	23	63	120	25
290	19 x 75	WN/22252	24	64	140	15
384	19 x 75	WN/22252	24	64	140	27
479	19 x 75	WN/22252	24	64	140	36
574	19 x 75	WN/22252	24	64	140	45
252	20 x 56	766	25	65	140	12
287	20 x 56	766	25	65	140	18
322	20 x 56	766	25	65	140	23
315	20 x 70	764	25	65	140	20
359	20 x 70	764	25	65	140	30
403	20 x 70	764	25	65	140	32
332	22 x 86	WN/22252	27	73	140	45
386	22 x 86	WN/22252	27	73	140	51
441	22 x 86	WN/22252	27	73	140	54
550	22 x 86	WN/22252	27	73	140	80
328	23 x 64	28		74	140	25
369	23 x 64	28		74	140	28
410	23 x 80	28		74	140	55
461	23 x 80	28		74	140	65
374	26 x 73	32		82	160	30
420	26 x 73	32		82	160	45
466	26 x 91	32		82	160	55
524	26 x 91	32		82	160	70
431	30 x 84	36		96	200	68
671	30 x 105	36		96	200	150
454	36 x 101	42		112	200	110
726	36 x 126	42		112	220	190
680	42 x 118	50		130	220	185
847	42 x 147	50		130	220	260

Other dimensions and qualities on request, WN = works standard

## Chain wheels, toothless in steel

- wide chain supports surfaces
- for diverting the chain

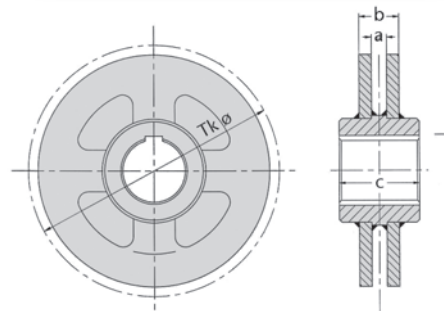

Chain wheel, toothless, steel, type GUA, replaceable rims.

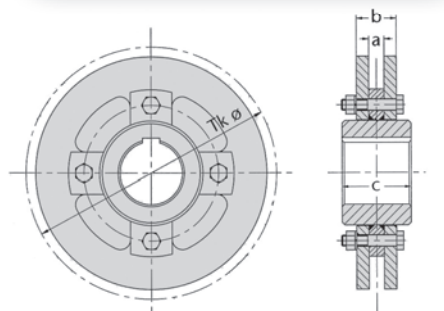

Chain wheel, toothless, steel, type GUE, one-piece.

DROP FORGED



DROP FORGED

# Technical information

## Erection – Maintenance – Wear

### Assembly instructions for chains

**Assembly:**

2-strand conveyor chains are always supplied as matched pairs. Chains for multi-strand conveyors, 3-4 strands, are supplied in matched bundles. Bundles are tied together with coloured wire, colour dependent on chain quality, as follows:

GEHA 280E – white

GEHA 21 – yellow

GEHA 210E black

GEHA 400E green

GEHA 5 red

GEHA 350E blue

It is important that the coloured wires are only removed immediately before assembly. Chain strands are then assembled in parallel which minimises the total length difference between the assembled chain strands. Chains should be assembled with the welds of the vertical links pointing towards the shaft centre of the chain wheel. Bolted scraper connections should be checked and re-tightened after the conveyor has been operated for several days on load and run in. Equal scraper bar length is essential for proper chain transport and

smooth operation. The shafts of the drive and idling wheels must be properly aligned and the wheel centres must also be in line. Chain tension should be minimised. Excess noise and/or vibration indicate excessive chain tension.

**Chain shortening:**

Should it be necessary to shorten the chain, then either a complete set of chain links is to be removed from both sides or with endless chain an equal number of links are removed from both chain strands. Heating of the adjacent chain link is to be avoided and cold cutting by using a cutting disc is preferred. Welding to the chain link, attachment and scraper bar is to be avoided. Please contact us in case of queries.

**Maintenance / Wear Measurement:**

All conveyor parts which may be subject to wear (wheels, chains, attachment, scraper bars) should be checked regularly for wear or damage. Chain contact surfaces are subject to normal wear, the extent of which is governed by chain quality, number of link movements, contact load and

material handled. Wear in the contact areas reduces the chain thickness and thus has a direct relationship to service life. Lubrication, for example with oil, increases wear as it will form a grinding paste. Air and water washes or scrapers, which remove the material from the chains, drive and idling wheels reduce wear. Chains and attachments should be checked for damage following a conveyor overload. Chain replacement should always be combined with the replacement of all toothed wheels, or toothed rims, to ensure proper meshing of the chain.

**Operational information:**

We recommend the installation of overload protection, e.g. shear pin, or overload coupling, as part of the drive unit to prevent overload of the chain during blockages in the conveyor. Material should be fed evenly over the whole width of the conveyor to avoid on sided loading and wear.

### Assembly instructions for chain wheels

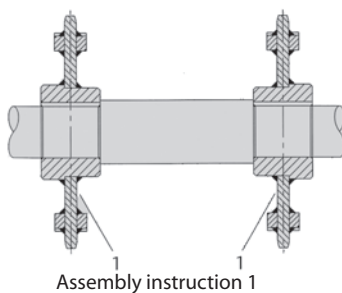

Assembly instruction 1

**Assembly instruction 1 for chain wheels on-piece**

Unless otherwise instructed in client's order, keyways will be cut in a pair of wheels central to a tooth. Chain wheels belonging together will be given the same number so that mistakes are avoided even with large numbers of wheels. Each pair of wheels will be marked with the same number sequence.

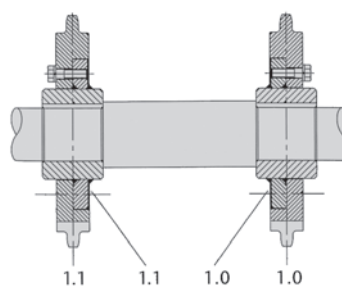

Assembly instruction 2

**Assembly instruction 2 for chain wheels with replaceable toothed rims**

Unless otherwise instructed in client's order, keyways will be cut in a pair of wheels central to a tooth. Chain wheels belonging together will be given the same number so that mistakes are avoided even with large numbers of wheels. Each pair of wheels will be marked with the same number sequence.

Each part of wheels with replaceable segments will be marked with an additional number, starting on the inside.



# 1) Round link chains for multi - purpose acc. DIN 766

For transmission, hand-chain, etc...

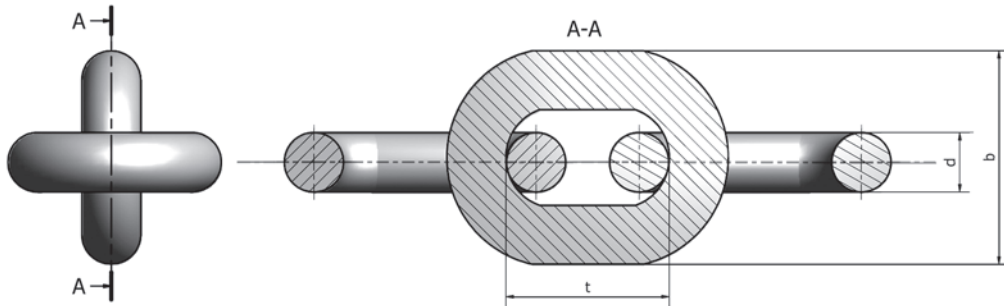

DROP FORGED

$\varnothing d$	t (pitch) mm	b mm	normal steel breaking-load Kg	heat-treated steel breaking-load Kg	weight Kg/m
4	16	14	600	---	0,320
5	18,5	17	1000	1260	0,500
6	18,5	20,4	1400	1800	0,750
8	24	27,2	2500	3200	1,35
10	28	36	4000	5000	1,80
13	36	47	4480	6400	3,80
16	45	58	10000	12600	5,80
18	50	65	12600	16000	7,30
20	56	72	16000	20000	9,00
23	64	83	20000	26800	12,00
26	73	94	25200	34000	15,00
30	84	108	34000	44800	20,00
33	92	119	40000	52800	24,50
36	101	130	50000	60000	29,00

bigger sizes on request

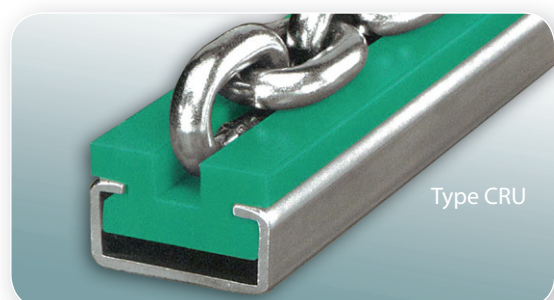
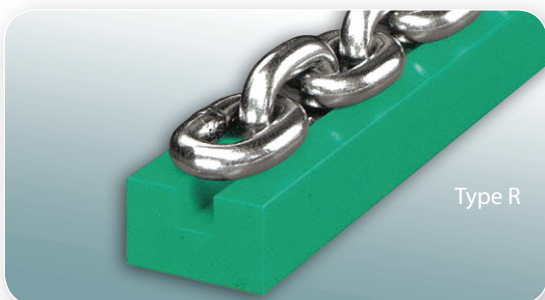
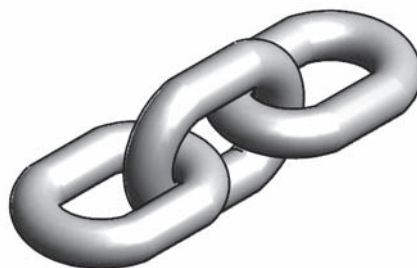

Slide-guide for round link chain also available



## 2) Round link chains for multi - purpose acc. DIN 764

For small conveyors, etc...

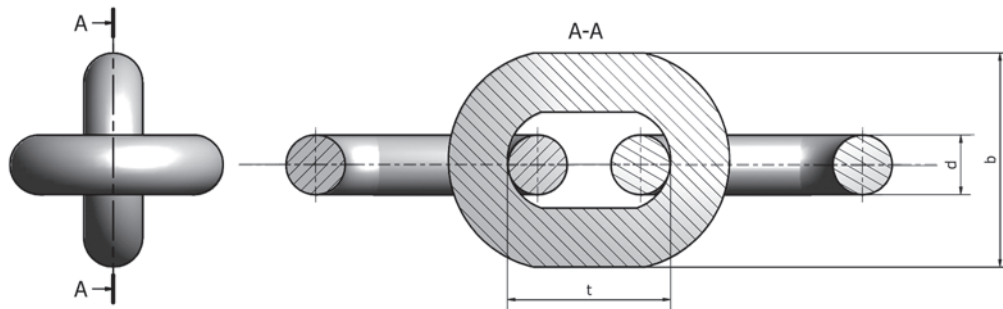

DROP FORGED

$\varnothing d$	$t$ (pitch) mm	$b$ mm	normal steel breaking-load Kg	heat-treated steel breaking-load Kg	weight Kg/m
10	35	36	4000	5000	2,05
13	45	47	6400	8480	3,45
16	56	58	10000	12600	5,20
18	63	65	12600	16000	8,20
20	70	72	16000	20000	8,20
23	80	83	20000	26800	10,80
26	91	94	25200	34000	14,00
30	105	108	34000	44800	19,00
36	126	130	50000	60000	26,50
39	136	140	56000	72000	31,00
42	147	151	68000	80000	36,00

If other qualities and/or other heat-treatments needed, please contact us.

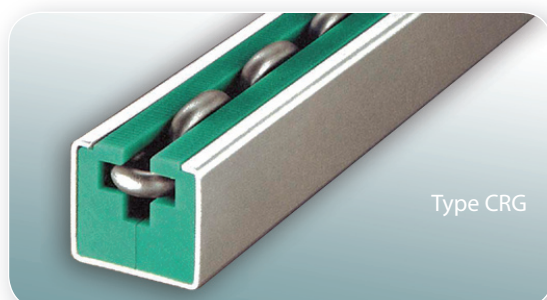
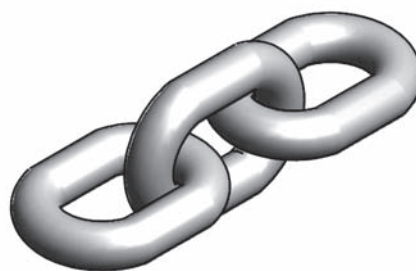

Type CRG

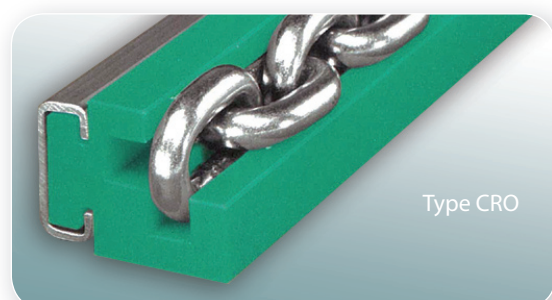

Type CRO

Slide-guide for round link chain also available



# Cast sprockets for round - link chain

Material GG25

DROP FORGED

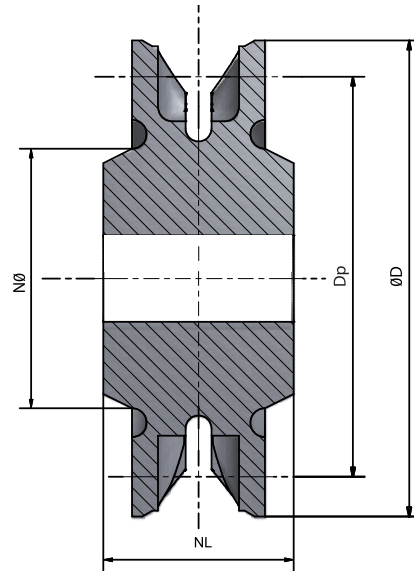
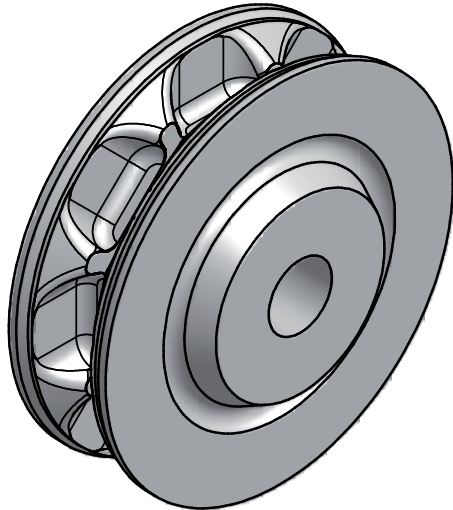

$d$ Ø chain	$t$ pitch	Z number of teeth	$D_p$	$D$	$b$	$N \varnothing$	NL	Weight/pce. Kg
<i>dimensions in mm</i>								
4	16	4	41	56	23	40	30	0,30
(DIN 766)		8	81	96	23	50	35	1,00
		12	122	140	23	50	40	1,50
		15	153	165	23	50	40	2,40
		18	183	200	23	50	40	2,60
5 & 6	18,5	6	71	95	32	50	50	1,20
(DIN 766)		7	82	110	32	60	50	1,90
		8	94	120	32	50	50	2,00
		10	118	135	32	60	50	2,40
		12	141	165	32	60	50	3,20
		14	165	185	32	65	50	3,90
		15	177	200	32	65	50	3,20
		16	188	215	32	60	50	3,80
		18	212	235	32	60	50	5,00
		19	224	250	32	60	55	5,00
		20	236	260	32	60	50	4,50
		24	283	300	32	60	50	5,20
		26	306	335	32	70	60	7,20
		28	330	360	32	70	60	7,10
		30	353	380	32	70	60	9,00
		32	377	410	34	70	60	10,50
		34	400	435	34	70	60	10,00
		36	424	450	34	80	70	12,00
		38	448	480	34	80	70	14,00
		40	470	500	38	100	75	17,00
		43	503	530	38	90	80	18,00
45	530	570	38	90	75	19,00		
50	589	620	38	100	70	25,00		
60	707	732	40	100	90	31,00		
65	766	810	40	155	75	46,00		



## Cast sprockets for round - link chain

Material GG25

$d$ Ø chain	$t$ pitch	$Z$ number of teeth	$D_p$	$D$	$b$	$N$ Ø	NL	Weight/pce. Kg
<i>dimensions in mm</i>								
8	24	5	76	105	45	80	65	2,30
(DIN 766)		6	92	115	45	80	65	3,00
		7	107	115	45	80	65	3,40
		8	122	162	45	80	65	4,60
		10	153	180	45	80	65	4,80
		12	183	212	48	80	65	6,00
		14	214	245	48	80	65	7,50
		16	244	275	48	90	70	9,00
		18	275	305	48	90	70	11,00
		20	306	345	48	90	70	13,00
		24	367	390	48	120	70	15,00
		28	428	450	48	-	-	17,00
		30	458	495	48	-	-	19,00
		32	489	530	48	90	-	21,00
		38	581	610	50	100	75	25,00
10	28	5	89	115	50	60	65	3,00
(DIN 766)		8	140	170	50	80	65	6,50
		12	214	250	52	140	75	14,00
		24	428	450	56	100	70	19,00
		10	35	7	157	193	55	80
(DIN 764)		10	224	260	55	100	75	10,00
		12	267	295	55	100	75	13,00
		14	314	350	55	100	-	19,00
		16	357	400	55	100	75	24,00
		18	401	435	55	100	75	24,00
		20	446	475	55	120	75	26,00
		27	602	630	55	160	75	38,00
		10	50	15	478	510	55	100
(DIN 762)								
13	36	5	115	155	68	100	75	5,50
(DIN 766)		6	138	186	68	100	88	8,50
		7	160	205	68	100	75	10,00
		9	207	243	68	100	75	12,00
		11	252	270	68	100	75	14,00
		12	275	300	72	-	75	15,00
		14	321	370	72	100	80	24,00
		15	344	390	72	140	80	29,00
		28	642	692	72	180	155	84,00
		13	45	5	143	180	76	100
(DIN 764)		6	174	220	76	100	85	10,00
		7	200	243	76	100	85	15,00
		8	229	275	76	100	85	15,00
		9	258	300	76	120	90	17,00
		10	286	320	76	120	90	22,00
		11	315	358	76	120	90	23,00
		12	344	380	76	120	90	29,00
		14	401	445	76	120	90	36,00
		16	458	500	76	120	90	43,00
		18	516	540	76	120	90	50,00

DROP FORGED



## Cast sprockets for round - link chain

Material GG25

$d$ Ø chain	$t$ pitch	$Z$ number of teeth	$D_p$	$D$	$b$	$N$ Ø	$NL$	Weight/pce. Kg
<i>dimensions in mm</i>								
14	41	8	202	250	70	140	70	15,00
(DIN 766)								
16	45	5	146	190	82	110	90	10,00
(DIN 766)		6	172	225	82	110	90	13,00
		7	201	250	82	130	90	17,00
		8	229	278	82	110	90	18,00
		10	286	326	82	180	90	30,00
		16	56	6	214	270	82	100
(DIN 764)		7	250	300	82	100	-	17,00
		8	285	330	82	100	95	24,00
		10	358	415	82	120	-	39,00
		11	392	440	84	120	100	40,00
		12	428	475	84	120	100	41,00
		15	535	580	84	150	100	57,00
16	570	610	84	160	100	54,00		
18	50	6	191	250	88	120	95	18,00
(DIN 766°)		8	255	310	88	120	95	32,00
		9	287	330	88	120	95	45,00
		18	63	9	361	418	95	150
(DIN 764)		10	402	455	90	170	145	60,00
		14	562	620	90	160	100	70,00
		20	56	6	214	285	100	140
(DIN 766)		8	285	320	100	140	110	32,00
		20	70	10	446	510	110	160
(DIN 764)								
20	100	7	447	500	100	190	125	70,00
(DIN 762)								
23	64	8	326	390	120	160	130	48,00
(DIN 766)								

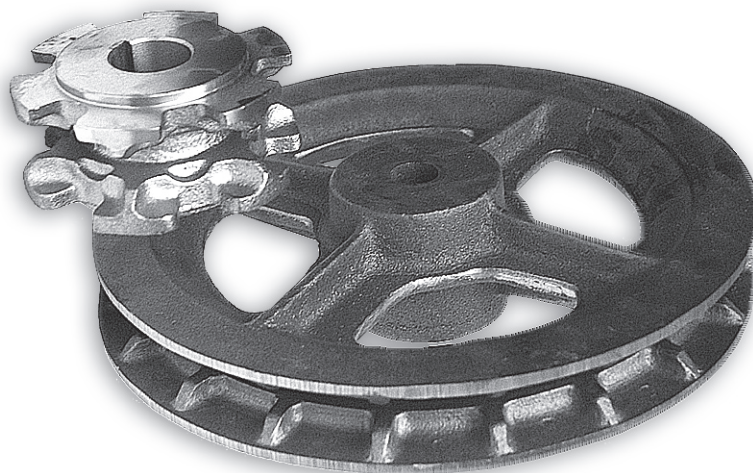

DROP FORGED



## Coupling chain system

The only chain doubling the ultimate tensile stress by keeping dimensions unchanged.

Thanks to the application versatility of this system, drive gears do not need to be changed and loads can be increased gradually up their doubling.

### Chains pitch 80



### Chains pitch 100

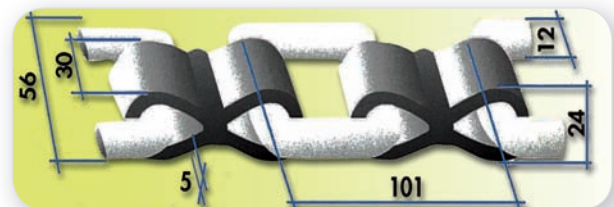

DROP FORGED

Breaking load	Kg. 6.500	Kg. 8.000	Kg. 9.000	Kg. 13.000
Chain type	80 / 12	80 / 12 / 5	80 / 12 / X	80 / 13 / X
Coupling 30x5	St. 44.2	St. 44.2	St. 52.3	St. 52.3
Link Ø 12	CK 10	20 Mn 5	20 Mn 5	19Mn B4 heat treatment
Joint				

Breaking load	Kg. 6.500	Kg. 8.000	Kg. 9.000	Kg. 13.000
Chain type	100 / 12	100 / 12 / 5	100 / 12 / X	100 / 13 / X
Coupling 30x5	St. 44.2	St. 44.2	St. 52.3	St. 52.3
Link Ø 12	CK 10	20 Mn 5	20 Mn 5	19Mn B4 heat treatment
Joint				





## Coupling chain system

**The wearproof high tensile steel chain.  
Strong elongation reduction.**

This chain can be welded by means of ordinary welding techniques, though being made of high tensile wear steel.

It can therefore be fitted with any additional parts.

DROP FORGED

### Chains pitch 80

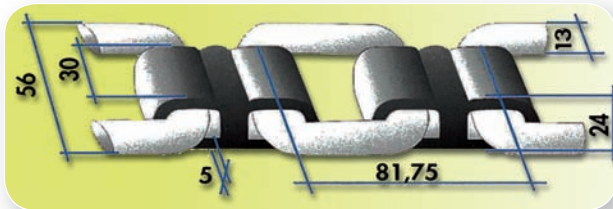

### Chains pitch 100



Breaking load  
Chain type

**Kg. 15.000**

**80 / 15 / X**

Coupling 30x5

**St. 52.3**

Link Ø 12

**25 Mn B5**  
heat treatment

Joint



Breaking load  
Chain type

**Kg. 15.000**

**100 / 15 / X**

Coupling 30x5

**St. 52.3**

Link Ø 12

**25 Mn B5**  
heat treatment

Joint





## Chains pitch 80

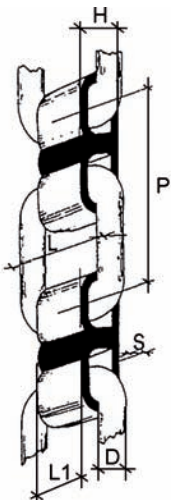
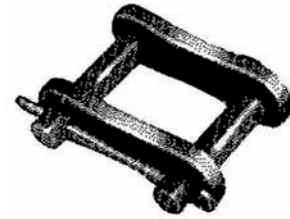
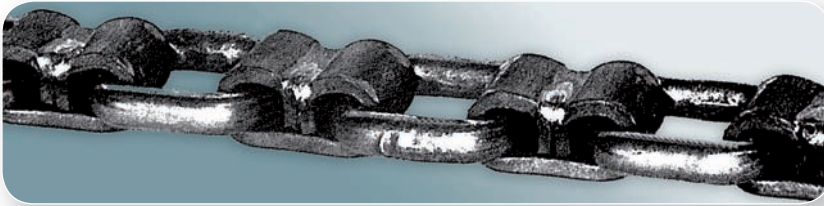

Chain No.	Pitch	Link diameter	Chain width	Coupling width	Coupling thickness	Coupling height	Breaking load	Material link	Material coupling	Weight meter
	P	D	L	L1	S	H	KG.			KG.
	mm	mm	mm	mm						
80/9	80,00	9,00	45,00	25,00	4,00	19,00	3500	CK 10	St. 44.2	2,30
80/11	81,75	11,00	54,00	30,00	5,00	24,00	6000	CK 10	St. 44.2	3,70
80/12	81,75	12,00	56,00	30,00	5,00	24,00	6500	CK 10	St. 44.2	4,00
80/12/S	81,75	12,00	56,00	30,00	5,00	24,00	7500	20 Mn 5	St. 44.2	4,00
80/12/X	81,75	12,00	56,00	30,00	5,00	24,00	8500	20 Mn 5	St. 52.3	4,00
80/13/X	81,75	12,00	56,00	30,00	5,00	24,00	13000	19 MnB 4	St. 52.3	4,00

Heat Treatment

DROP FORGED

## Chains pitch 80

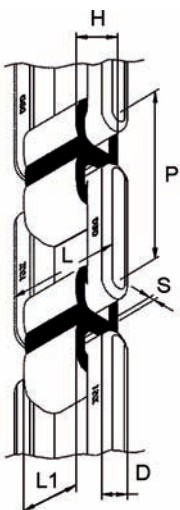
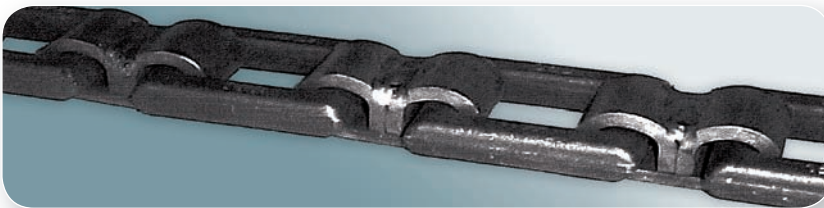

Chain No.	Pitch	Link diameter	Chain width	Coupling width	Coupling thickness	Coupling height	Breaking load	Material link	Material coupling	Weight meter
	P	D	L	L1	S	H	KG.			KG.
	mm	mm	mm	mm						
80/15/X	81,75	13,00	58,00	30,00	5,00	24,00	15000	25 MnB 5	St. 52.3	4,40

Chains for use on manurespreaders, forage-harvesters, self-loader trucks mats and low speed conveyor where economy, robustness and duration are required.  
Lengths and production in bundles of one, two or tree chains are defined according to various requirements.



## Chains pitch 100

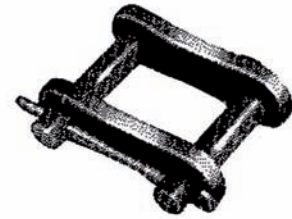
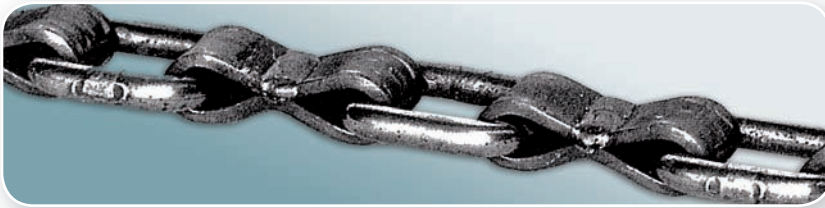

DROP FORGED

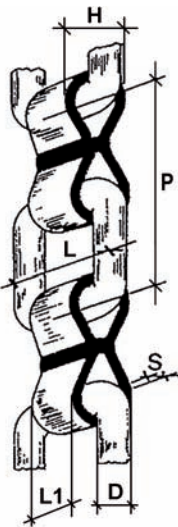

Chain No.	Pitch	Link diameter	Chain width	Coupling width	Coupling thickness	Coupling height	Breaking load	Material link	Material coupling	Weight meter
	P	D	L	L1	S	H	KG.			KG.
	mm	mm	mm	mm						
100/11	101,00	11,00	54,00	30,00	5,00	24,00	6000	CK 10	St. 44.2	3,15
100/12	101,00	12,00	56,00	30,00	5,00	24,00	6500	CK 10	St. 44.2	3,45
100/12/S	101,00	12,00	56,00	30,00	5,00	24,00	7500	20 Mn 5	St. 44.2	3,45
100/12/X	101,00	12,00	56,00	30,00	5,00	24,00	8500	20 Mn 5	St. 52.3	3,45
100/13/X	101,00	12,00	56,00	30,00	5,00	24,00	13000	19 MnB 4	St. 52.3	3,45

Heat treated

## Chains pitch 100

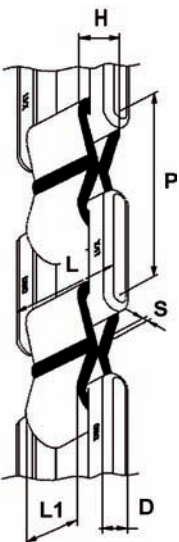

Chain No.	Pitch	Link diameter	Chain width	Coupling width	Coupling thickness	Coupling height	Breaking load	Material link	Material coupling	Weight meter
	P	D	L	L1	S	H	KG.			KG.
	mm	mm	mm	mm						
100/15/X	101,00	13,00	58,00	30,00	5,00	24,00	15000	25 MnB 5	St. 52.3	3,85

Chains for use on manurespreaders, forage-harvesters, self-loader trucks mats and low speed conveyor where economy, robustness and duration are required.

Lengths and production in bundles of one, two or three chains are defined according to various requirements.



## Sprockets



DROP FORGED

Chain No. 	N° teeth	Pitch	Prim. diameter	Thickness teeth	Bore diameter	Material
	Z	P mm	DP mm	S mm	D mm	
73/4	4	73,00	94,00	20,00	30-35-40	Steel / Fe 430 B
73/5	5	73,00	94,00	20,00	30-35-40	Steel / Fe 430 B
80/4 X 9	4	80,00	102,00	20,00	30-35-40	Steel / Fe 430 B
80/4 X 12	4	81,75	103,00	23,00	30-35-40	Steel / Fe 430 B
80/5	5	81,75	130,00	23,00	30-35-40	Steel / Fe 430 B
					50-55-61	
80/5G	5	81,75	130,00	20,00	30-35-40	GG 25
80/6 X 9	6	80,00	153,00	20,00	On request	Steel / Fe 430 B
80/6 X 12	6	81,75	155,00	25,00	45	Steel / Fe 430 B
80/8	8	81,75	207,00	25,00	On request	Steel / Fe 430 B
80/10	10	81,75	258,00	25,00	On request	Steel / Fe 430 B
80/12	12	81,75	311,00	25,00	On request	Steel / Fe 430 B
90/4	4	93,00	118,00	25,00	On request	Steel / Fe 430 B
100/5	4	101,00	129,00	25,00	45	Steel / Fe 430 B
100/4G	4	101,00	129,00	25,00	30-35-40	GG 25
*90/5EG	5	90,00	144,00	18,00	20	GG 25
*90/6EG	6	90,00	173,00	18,00	20	GG 25

\* Only for pitch 90 light series chain.

The types of sprockets indicated in the table are standard production.

Sprockets with numbers of teeth and thicknesses which are different from those indicated can be manufactured according the various requirement.